



**ELECTRIC VEHICLE CHARGER
EVC16 SPICA L SERIES**

Installation Guide



CONTENTS

1 - SAFETY INFORMATION	3
1.1 - SAFETY WARNINGS	3
1.2 - FIRE FIGHTING INSTRUCTIONS FOR ELECTRIC VEHICLE CHARGING STATION	5
1.3 - GROUND CONNECTION WARNINGS	5
1.4 - POWER CABLES, PLUGS, AND CHARGING CABLE WARNINGS	5
1.5 - PROTECTIONS REQUIRED BEFORE SYSTEM.....	6
2 - MODEL DESCRIPTION	7
3 - GENERAL INFORMATION.....	8
3.1 - INTRODUCTION OF THE PRODUCT COMPONENTS	8
3.2 - DIMENSIONAL DRAWINGS	9
3.3 - LCD DISPLAY	10
3.4 - PRODUCTS WITH CERTIFIED ENERGY METER	11
3.5 - TYPE PLATE	12
3.6 - PUBLIC KEY.....	12
4 - TECHNICAL SPECIFICATION.....	14
5 - USER INTERFACE & AUTHENTICATION.....	14
6 - CONNECTIVITY	14
7 - MECHANICAL SPECIFICATIONS	15
8 - ENVIRONMENTAL SPECIFICATIONS.....	15
9 - TECHNICAL SPECIFICATIONS OF THE MEASUREMENT CAPSULE	16
10 - REQUIRED EQUIPMENT, INSTRUMENTS AND ACCESSORIES.....	17
10.1 - SUPPLIED INSTALLATION EQUIPMENT, TOOLS AND ACCESSORIES.....	17
10.1.1 - SUPPLIED BY INSTALLER.....	17
10.2 - RECOMMENDED EQUIPMENT AND TOOLS	18
11 - INSTALLING CHARGING STATION	19
11.1 - UNPACK THE CHARGING STATION	20
11.2 - FOUNDATION, ALIGNMENT, LAYOUT	21
11.3 - ESTABLISHMENT OF THE STATION BY PREPARING THE CONCRETE AND ANCHOR PLATE..	24
11.4 - OPENING THE FRONT COVERS	26
11.5 - CABLE ASSEMBLY	26
11.5.1 - OPENING THE FRONT COVER AND CABLE CONNECTION	26
11.5.2 - SIM CARD CONNECTION (OPTIONAL)	28
11.6 - COMMISSIONING	31
11.6.1 - CONNECTING OCPP THROUGH ETHERNET NETWORK	29
11.6.2 - CONNECTING TO THE SAME NETWORK WITH THE ETHERNET PORT.....	29
11.6.3 - OPENING WEB CONFIGURATION INTERFACE WITH BROWSER	30

11.6.4 - WEB CONFIGURATION INTERFACE	31
11.6.4.1 - GENERAL SETTINGS	32
11.6.4.2 - OCPP SETTINGS	33
11.6.4.3 - NETWORK INTERFACES	33
11.6.4.4 - POWER MANAGEMENT	33
11.6.4.5 - SYSTEM MAINTENANCE	34
11.7 - CLOSING THE COVER	35
12 - CHECKING THE VALIDITY OF THE MEASUREMENT	36
13 - OVERVIEW OF THE CHARGING STATION WITH DESCRIPTION OF THE MANUFACTURER'S/ OPERATOR'S SEALS	44
13.1 - SEALS OF THE MANUFACTURER	44
13.2 - RECOMMENDED POSITION OF THE OPERATOR SEAL	45
14 - LEGAL INFORMATION	46
14.1 - MEASUREMENT ACCURACY NOTES ACCORDING TO CSA TYPE EXAMINATION CERTIFICATE.....	46
15 - MAINTENANCE	49
16 - PERIODIC MAINTENANCE LIST	49
17 - WIRELESS LAN TRANSMITTER SPECIFICATIONS	51

1 - SAFETY INFORMATION



CAUTION THE RISK OF ELECTRIC SHOCK



CAUTION: THE ELECTRIC VEHICLE CHARGER CAN ONLY BE INSTALLED BY A LICENSED OR EXPERIENCED ELECTRICIAN BY THE ELECTRICAL REGULATIONS AND STANDARDS OF ANY RELATED REGION OR COUNTRY.



CAUTION



The AC grid connection and the electric vehicle charger's load plan are examined and approved by the electrical regulations and standards of the related region or country determined by the authorities.

In the installation of multiple electric vehicle chargers, the load plan will be determined accordingly. The manufacturer shall not be liable in any way, directly or indirectly, for damages or risks caused by the errors that may occur due to AC grid connection or load planning.

CAUTION: FOR DEVICES WITHOUT EMERGENCY BUTTON;

If any suspicious or emergency situation arises at the charging station aside from normal operation, start by halting the charging process through the vehicle (using the appropriate switch or button, which may vary depending on the model), and then disconnect the socket. As an alternative option, consider switching off the MCCB or RCCB in the panel where the product is energized by the installer.

IMPORTANT - Read these instructions fully before installation or operation.

1.1 - SAFETY WARNINGS

- Keep this manual in a safe place. These safety and operating instructions should be kept in a safe place for future reference.
- Check the voltage specified on the rating plate and do not use the charging station without the proper mains voltage.
- Do not continue to use the unit if you have any doubts as to whether it is working normally. If the device has been damaged in any way, switch off the main supply circuit breakers (MCCB and RCCB) in the upstream distribution board. Consult your local dealer.
- During charging, the ambient temperature range (without direct sunlight) should be between -35 °C and +55 °C and the relative humidity should be between 5% and 95%. Use the charging station only within the specified operating parameters.
- The device location should be consciously selected in order to prevent the charging station from overheating. High temperature caused by direct sunlight or heating sources during use may cause the charging current to decrease or the charging process to be temporarily interrupted.
- The charging station is made for indoors and outdoors. It can also be used in public open spaces.

- To reduce the risk of fire, electric shock, or product damage, do not expose the unit to heavy rain, snow, lightning storms or other harsh weather conditions. Furthermore, liquids should not be spilled or splashed on the charging station.
- Do not touch the end terminals of the charging station, the electric vehicle connector and other dangerous current parts with sharp metal objects.
- Avoid exposing the unit to heat sources and place it away from flammable, explosive, hard or caustic materials, chemicals or steam.
- Explosion Risk. This equipment contains internal spark or spark-generating parts and must not be exposed to flammable vapours. It should not be placed in lowered or below ground level locations.
- Make sure that the specified Current Switch and RCD are connected to the building mains to prevent the risk of explosion and electric shock.
- The base part of the charging station should be at (or above) ground level.
- Adapters or converter adapters cannot be used. Cable extension sets cannot be used.
- Use this product at an altitude of not more than 2000 meters above sea level.
- Do not place objects containing liquids, such as glasses and bottles, on the product.
- Against the risk of choking, keep the plastic packaging materials out of the reach of babies, small children and pets.
- Do not wash the device with water.
- Do not use abrasive fabrics, wet cloths, alcohol or detergents. Microfiber fabric is recommended.
- Keep the door lock key, which enables the product panel to be opened and prevents access to electrical parts, out of the reach of small children.
- It should be kept in its original box to prevent damage to device components during transport.
- Defects and damages that occur during transportation after the device shipment to the customer are not covered by the warranty.
- The allowed current value of the service socket is a maximum of 10A.
- Please adhere to the rope warnings outlined in the “Basic Alignment and Layout” section, especially when transporting the product.



WARNING : Persons (including children) who are physically, perceptually or mentally incompetent or inexperienced should not use electrical devices without the supervision of a person responsible for their safety.



CAUTION: This vehicle charger is designed only for charging the electric vehicles that do not require ventilation during charging.

1.2 - FIRE FIGHTING INSTRUCTIONS FOR ELECTRIC VEHICLE CHARGING STATION

- **Personal Safety:** If you observe a fire or notice any danger signs, prioritize your safety above all else. Do not take unnecessary risks.
- **Notify Emergency Services Immediately:** Contact your local emergency services. Dial the emergency number 998 or 112.
- **Stopping the Charging Process:** If it is safe, disconnect the charging cable from the vehicle and the charging station.
- **Use of Fire Extinguishing Agents:** If a fire extinguisher or other firefighting equipment is nearby and you are trained to use it, attempt to extinguish the fire. However, never risk your own safety.
- **Avoid Direct Contact with Fire:** Do not try to extinguish a fire unless you have the appropriate equipment, training, or knowledge, or if the fire is exceptionally large or dangerous.
- **Move Away from the Station:** If the fire cannot be controlled or is intensifying, evacuate from the charging station while maintaining a safe distance.
- **Avoid Inhaling Smoke:** Try to avoid breathing in smoke. If possible, cover your nose and mouth with a damp cloth or clothing.
- **Warn Others in the Area:** Alert others nearby about the fire hazard and urge them to evacuate the area.
- **Wait for Emergency Services:** After safely evacuating the area, wait for emergency services to arrive in a secure location.
- **Do Not Return to Station Facilities:** Do not re-enter the charging station building until emergency services have concluded their operations.
- **Reporting the Incident:** Contact customer support to report the incident.

Remember, safety is always the top priority. In the event of a fire, always seek guidance from local emergency services and adhere to their instructions.

1.3 - GROUND CONNECTION WARNINGS

- The charging station should be connected to a central grounding system. The grounding conductor entering into the charging station should be connected to the equipment grounding lug inside the charging station. This should be powered by the circuit conductors and connected to the equipment grounding rod or to the guide member at the charging station. Connections to the charging station are in the charge of the installers and purchasers.
- Connect it only to correctly grounded plugs to reduce the risk of electric shock.
- **WARNING :** Make sure that the charging station is permanently and properly grounded during installation and use.

1.4 - POWER CABLES, PLUGS, AND CHARGING CABLE WARNINGS

- Note that the plugs and sockets in the charging station are compatible.
- A damaged charging cable may cause a fire or electrical shock conditions. Do not use this product if the Flexible Charging cable or vehicle cable is worn, has frayed insulation, or shows any different signs of damage.
- Make sure the charging cable is well placed, thus you will not step on and trip over the cable or the cable will not damage or subject to stress.

- Do not forcibly pull on the charging cable or damage the cable with sharp objects.
- Never touch the electric cable/plug or vehicle cable with wet hands as this may cause a short circuit or electric shock.
- To avoid the risk of fire or electric shock, do not use this device with an extension cable. In case of damage to the mains cable or vehicle cable, the cables should be replaced by the manufacturer, service agency or similar qualified persons to prevent any hazards.
- Use appropriate protection while connecting the device to the main power distribution cable.

1.5 - PROTECTIONS REQUIRED BEFORE SYSTEM

- Class I/B Lightning Protection should be connected to the upstream distribution board. It is recommended that the cable length between the charger and the protection device be at least 10m. *The charger is equipped with a Class II/Type C Surge Protective Device (SPD).
- To prevent the residual current, Type A residual current relay with toroidal sensor should be used on the panel before the device. The minimum current sensitivity should be set to 300mA.

Model	Power	Input Voltage	Maximum Input AC current	Recommended Minimum Neutral Conductor Cross-Section (Cu)
EVC16-DC160CC	160kW	400V (nom.)	247A	16mm ²
		360V (-%10)	274A	

- Cable cross-sections must be selected by the installer in accordance with local and international standards, taking into account the specified minimum and maximum AC input current values, installation distances, and mounting location conditions.
- The PE cable cross-section should be at least half of the phase cable cross-section.
- It is recommended to use a CAT6 SFTP Ethernet cable.
- Cables must be suitable for outdoor use.
- Cables must be UV-protected and suitable for installation in underground conduits in compliance with local regulations.
- The AC input cable glands supplied with the product are suitable for cables with diameters in the range of 22–32 mm.

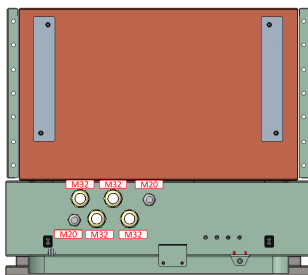

- SKP dimensions for AC line connections are provided below.

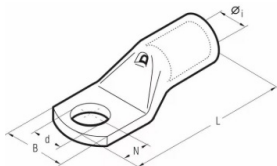

SKP	Øi	B	N	L	d
M8	21.1mm	39.0mm	11.0mm	77.5mm	8.4mm

2 - MODEL DESCRIPTION

This product was developed for charging electric vehicles with a suitable charging system in accordance with the IEC 61851-1 standard for the pilot standard signal. This document describes the specific functions and characteristics of the corresponding variants of charging stations and measuring devices in relation to electrical energy in accordance with § 46 of the German Measurement and Verification Ordinance (MessEV), taking into account PTB-A 50.7 and PTB-REA document 6-A.

Only the following models are certified in accordance with MessEG and MessEV:

EVC16-DC*-EICH**

In accordance with the German Measurement and Calibration Act, the charging station can be billed according to kWh. You can consult the German Measurement and Verification Act, which is described in **chapter 14**

Model Name	<u>EVC16-DC-Series (Name coding: EVC16-DC***-EICH)</u>
	1. Asterisk (*) : Nennleistung 160 : 160 kW DC Power Output 2. Asterisk (*) : DC output combination 1 C : CCS Output 3. Asterisk (*) : DC output combination 2 C : CCS Output
Cabinet	EVC16-DC160

3 - GENERAL INFORMATION

3.1 - INTRODUCTION OF THE PRODUCT COMPONENTS

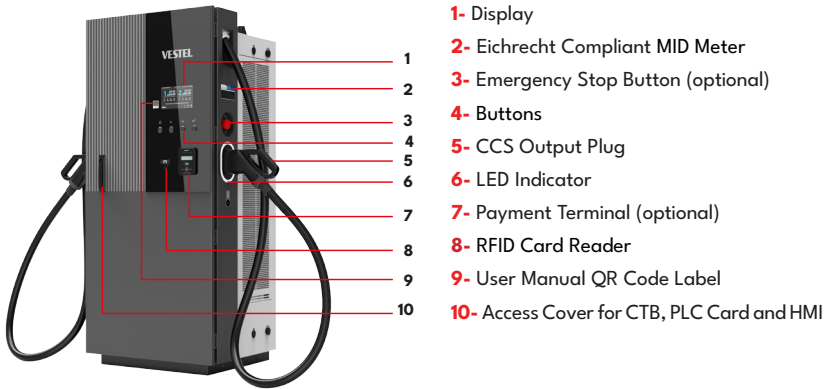

All products images are given for representative purpose only.

3.2 - DIMENSIONAL DRAWINGS

Front, Side and Top View

RIGHT SIDE VIEW

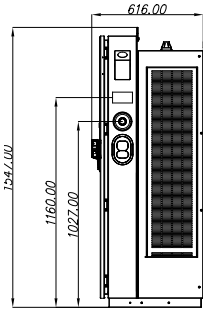

FRONT SIDE VIEW

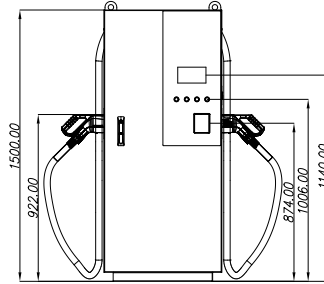

LEFT SIDE VIEW

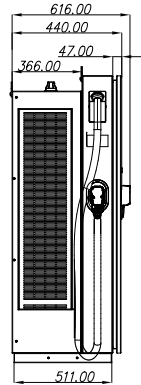

BACK SIDE VIEW

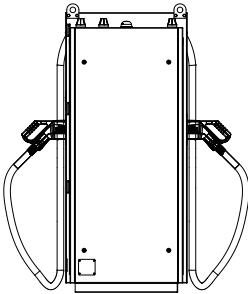

TOP SIDE VIEW

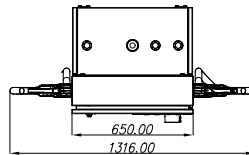

3.3 - LCD DISPLAY

This display can be used to show the various measured values and the associated units and registers in plain text.

PRODUCT START DISPLAY

Screen	Description
 S/N: 012004000155545	Company logo Serial number of the device
Firmware versions: Meter Unit LR 2.3.0.1 Sensor Unit LR 0.0.8.0 Meter Unit LNR 2.3.0.1	Identifiers of the DCBM firmware versions
Firmware checksums: Meter Unit LR 7B595E04395 39EECE15E856 Sensor Unit LR 540F	Integrity checks for legally relevant firmware components
Public key: ED7454F27FE39902A823 C3CC87E5CF8755310008 16A4404470C8E80C8034 4C8E4100567013E595F7 9FD991463A53E4E1205 80F59558062CE4D2E127 B46835B8	Public key of the device, for authentication in LEM format (i.e. without OCMFRFC5480 header), public key with OCMF format is encoded in the data matrix on the front of the device.
Screen test	Test screen

3.4 - PRODUCTS WITH CERTIFIED ENERGY METER

RFID/Autocharge and credit card (optional) authentication methods have different information on the meter display energy register at the beginning of the transaction.

RFID/Autocharge



Credit card



Date and time on site at the start of the transaction Total duration of the transaction.

RFID/Autocharge

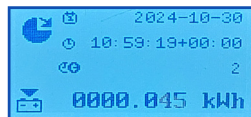

Credit card

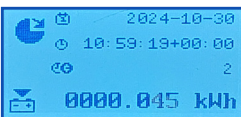

Kunden RFID/Autocharge ID

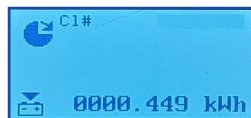

Customer Credit card ID

Prefix of the charging station operator, followed by the first 6 digits and the last 4 digits of the credit card ID.

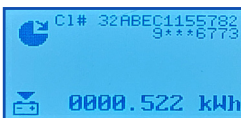

Cable compensation, EVSE identification input and chargepoint ID_Sw version_tariff (chargepointid_Sw version_tariff) with currency.

RFID/Autocharge

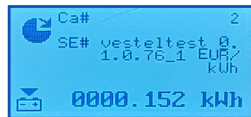

Credit card

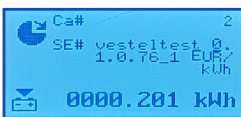

Energy register at the end of the transaction.

RFID/Autocharge

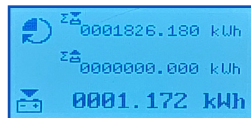

Credit card

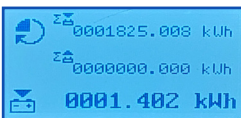

All products images are given for representative purpose only.

4 - TECHNICAL SPECIFICATION

Model		EVC16-DC160CC-EICH
IEC Protection class		Class - I
IEC EMC Class		IEC 61000-6-3 Class B - Residential (Emission) IEC 61000-6-2 Industrial (Immunity)
Input Rated Voltage and Current Value	Input Rating	230/400 V AC \pm 10%, 50/60 Hz, 250 A
	Connection	3 L+N+PE (TN, TT)
	Power Factor	> 0.98
	Efficiency	> %95
	Residual Current Protection	230 V AC RCBO 1P+N, Type A, 30 mA (System)
	Standby Power Consumption	< 80 W
CCS Output - 1	Max. Power	160kW • 1 x 160kW • 2 x 80kW
	Voltage Range	200 – 920V DC
	Maximum Current	500 A • 1 x 160kW 250 A • 2 x 80kW
	Minimum Current	6A
	Min. Energy for guaranteed accuracy	1 kWh
	Interface Compatibility	IEC62196-1 / 3 IEC 61851-1 / 23 / 24 ISO 15118-1 / 2 / 3 DIN 70121 REA-Document 6-A PTB-A 50.7 PTB A 50.8

CCS Output - 2	Max. Power	160kW <ul style="list-style-type: none"> • 1 x 160kW • 2 x 80kW
	Voltage Range	200 – 920V DC
	Maximum Current	500 A <ul style="list-style-type: none"> • 1 x 160kW 250 A <ul style="list-style-type: none"> • 2 x 80kW
	Minimum Current	6A
	Min. Energy for guaranteed accuracy	1 kWh
	Interface Compatibility	IEC62196-1 / 3 IEC 61851-1 / 23 / 24 ISO 15118-1 / 2 / 3 DIN 70121 REA-Document 6-A PTB-A 50.7 PTB A 50.8

5 - USER INTERFACE & AUTHENTICATION

Display	7" Color TFT LCD without Touch Screen (16:9)
User Interface	Illuminated buttons
RFID Reader Module	ISO/IEC 14443A/B and ISO/IEC15693
Payment module (Optional)	Options for contactless credit card equipment Please contact the following service providers regarding installation. https://www.payter.com/contact https://www.nayax.com/contact/
Eichrecht Compliant DC MID Meter	The charging device complies with Eichrecht.

6 - CONNECTIVITY

LAN Connectivity	Ethernet
WLAN Connectivity	2.4GHz/5GHz: 802.11 a/b/g/n/ac
Mobile Connectivity	GSM 900/1800 UMTS 900/2100 LTE-Band 1/3/7/8/20/28A
OCPP Specification	OCPP 1.6 J

7 - MECHANICAL SPECIFICATIONS

Material	Metal Panel	
Protection Degree	Ingress Protection Impact Protection	IP54 IK10
Cooling	Forced Air Cooling Fan	
Cable Length	CCS: 3,5 m CCS: 4,5 m (option)	
Dimensions (Product)	1500 mm (Height) x 650 mm (Width) x 560 mm (Depth)	
Dimensions (Packed version)	1750 mm (Height) 970 mm (Width) 600 mm (Depth)	
Weight (Product)	Net: 220 kg.	
Packed Weight	With Packing : 253 kg	

8 - ENVIRONMENTAL SPECIFICATIONS

Operating Condition	Temperature	-35°C to + 55 °C (Derating is applied over +40°C to +55 °C)
	Humidity	5% to 95% (Relative humidity, non-condensing)
	Altitude	0 - 2,000m



After the product has been powered at low temperatures, it should wait for the activation of the heating element in the charger, and the charging process should only be carried out afterwards.

9 - TECHNICAL SPECIFICATIONS OF THE MEASUREMENT CAPSULE



Model	DCBM NIM 6000 0000
Manufacturer	LEM
Sign of the type test certificate	DE-20-M-PTB-0075, Revision 5
Iref [A]	120
I_{max} [A]	600
I_{min} [A]	6
Meter constant [imp./kwh]	1000
Un [V]	150/1000 V
Operating temperature	-40 °C...+85 °C (Sensor Unit) -25 °C...+70 °C (Meter Unit) -40 °C...+85 °C (Data Cable)
Accuracy class	B
Firmware Version (Meter Unit)	2.3.0.1
Firmware Version (Sensor Unit)	0.1.3.0
Firmware checksum (Meter Unit)	0x7BE605E0439539EECE15E856
Firmware checksum (Sensor Unit)	0x3CBB

10 - REQUIRED EQUIPMENT, INSTRUMENTS AND ACCESSORIES













10.1 - SUPPLIED INSTALLATION EQUIPMENT, TOOLS AND ACCESSORIES

Special Switch M50 x M40	
Product control with internet connection(optional)	
1 set (x2) Lock Key	

10.1.1 - SUPPLIED BY INSTALLER

M16 Steel Dowel x4	
M20 special anchor bolt set (4 pcs) - Grade 8.8 (optional)	
Anchor plate (1 pc) - S235JR Steel + Hot Dip Galvanizing ($\geq 70 \mu\text{m}$) (optional)	

10.2 - RECOMMENDED EQUIPMENT AND TOOLS

			
Ø16 Drill Bit	Hammer Drill	PC	Phillips Screwdriver
			
13(M8) , 17(M10), 19(M12) Wrench	RJ45 crimping tool	Cat5e or cat6 ethernet cable	Hammer
			
M16 Steel Dowel x4	RJ45 Male Connector	T25 Screwdriver	20 - 200 Nm D:40mm H:43mm

11 - INSTALLING CHARGING STATION

Screws inside the product are recommended to be exceeding 240 hours Salt Fog test under ASTM B117 Method. Screws outside the product are recommended to be exceeding 720 hours.



WARNING: RISK OF ELECTRICAL SHOCK AND INJURY. POWER OFF THE CHARGING STATION MAIN SUPPLY BEFORE ANY INSTALLATION STEPS.



WARNING: TO AVOID PERSONAL INJURY OR DAMAGE THE CHARGING STATION, ENSURE THE INSTALLATION AREA IS SUITABLE AND THE FLOOR CAN WITHSTAND THE WEIGHT OF THE CHARGING STATION.

11.1 - UNPACK THE CHARGING STATION

Unpack the charging station as shown in the figure below.

Note that the front and top covers are marked as shown in the figures.

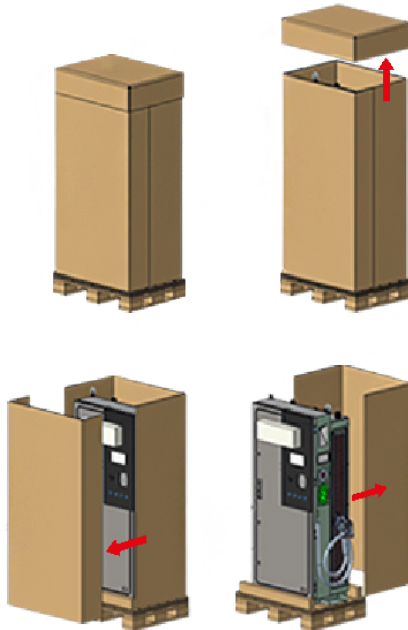

All products images are given for representative purpose only.

11.2 - FOUNDATION, ALIGNMENT, LAYOUT

The dimensions of the concrete foundation are as shown below:

NOTE: Anchoring to the ground with steel dowels is the standard method.

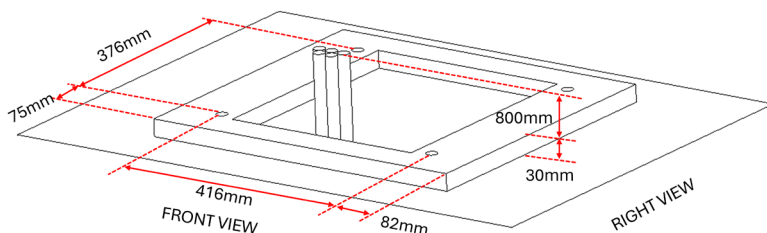

1. For installation, a minimum distance of 1 meter must be left from the right and left side of the device.
2. Dig a foundation pit in the ground according to the dimensions of the concrete foundation shown in the figure.
3. Drill a rectangular hole from top to bottom in the concrete foundation for the cables (3P+N+PE and Communication) from the mains supply. The dimensions and location of the concrete foundation are shown in the Figure.
4. The upper surface of the foundation should be at least 30mm above the ground.
5. Open the front cover of the product with the switches provided by turning the handle counterclockwise at a wide angle.
6. For the cable group in the cabinet, a cable length of 80 cm should be provided above the foundation.
7. Drill 4 holes on the concrete foundation with the dimensions shown in the figure and drive the M16x145 expansion bolt into these holes as shown in the Figure.
8. Remove the bottom plates (left and right) by unscrewing the plates.
9. In cases where the product needs to be transported; During lifting, it is necessary to use 2 ropes of min. 540mm (if a single rope of min. L=1080mm is used, the rope should be fixed at the middle lifting part).

During lifting, there should be a minimum angle of 60 degrees at both rope ends, as shown in the image. Using a shorter sling will cause damage to the product.

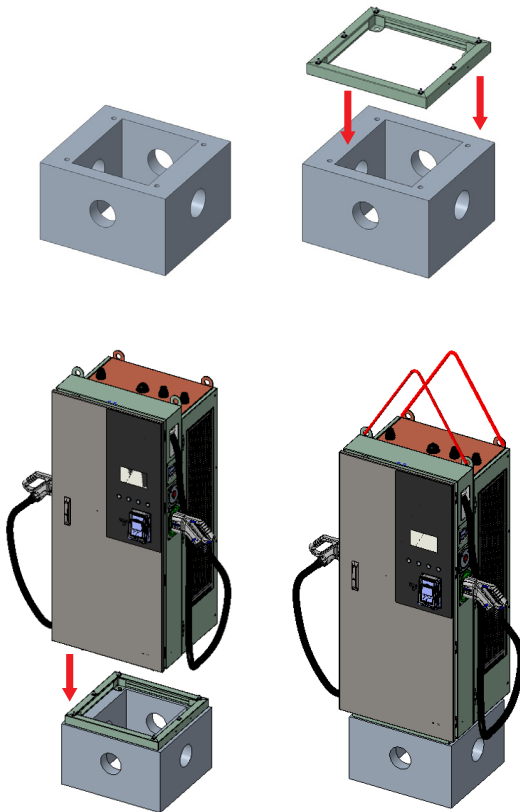
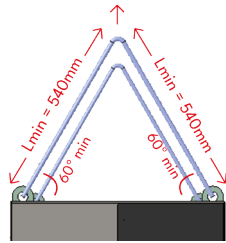

All products images are given for representative purpose only.

Hole Drilling Diameter: $\varnothing 16$ mm, Drilling Depth: 155mm (Torque: 200Nm)



M16

10. Remove the eye bolts after placing the charging station. Tighten the screws with setscrews as shown in the figure.

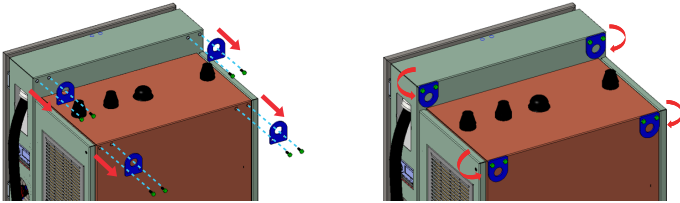

All products' images are given for representative purpose only

Concrete Dimension:

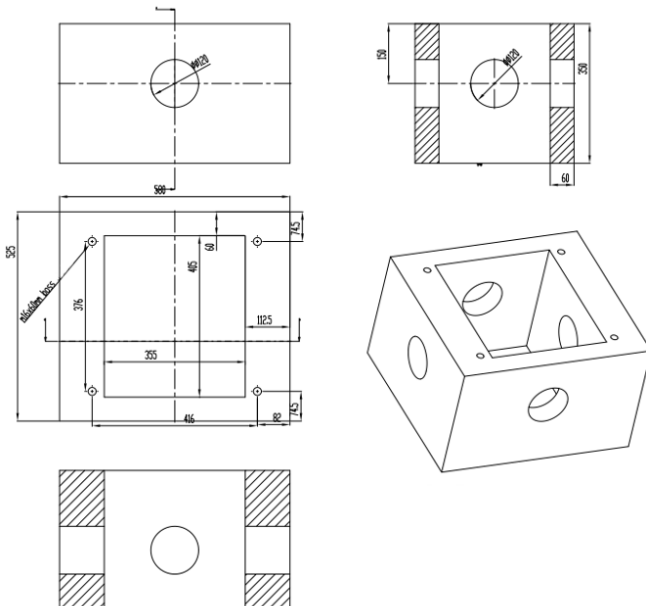

11.3 - ESTABLISHMENT OF THE STATION BY PREPARING THE CONCRETE AND ANCHOR PLATE

Make sure that the materials and installation procedures used for the concrete foundation comply with the local building codes and safety standards.

NOTE: The installer will supply this embedded metal plate and anchor system, and we are presenting this installation method as an alternative to comply with legal requirements.

For the Preparation and Mounting of the Anchor Plate, the following three steps should be followed as also shown in the figures:

1. Attach each nut one by one to each bolt as shown.
2. Attach the anchor plate to the bolts as shown in the figure.
3. Mount the nuts on the anchor bolt to secure with the bolts.

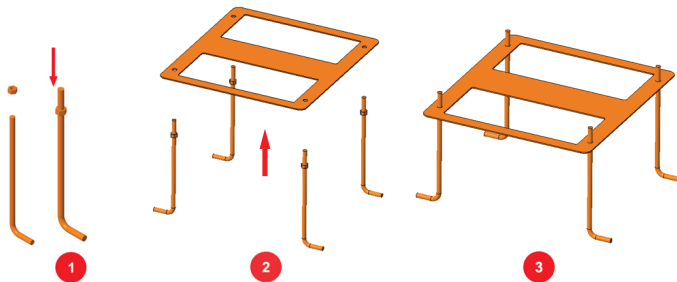

For the preparation of the installation site and wiring, the following steps should be followed as also shown in the figures:

1. Dig a pit for the anchor bolts and plate assembly (dimensions as: 525x580x320 – D_xW_xH mm). The ground of the pit should be grinded and horizontal.
2. Place the anchor arrangement in the pit.
3. Before the concrete is poured, the cables should be placed in the middle part and pulled through the sheet hole. Pull the supply cable and possible data cable through the floor mounting box cable glands and also through the mounting box cable hole. A minimum clearance of 500 mm for the AC mains cable and 0.5 meters for the ethernet cable should be left from the ground surface of the mounting box.
4. Fill the pit with concrete. Then set the mounting assembly as shown in the picture. The upper surface of the 2nd bolt should be at the concrete level. A level indicator can be used while adjusting.
5. Allow the concrete to solidify, note that the surface remains firm and flat during the process.
6. Place the charging station on the anchor plate as shown in the figure. Pass the cables through the cable glands.
7. Fix the charging station to the surface as shown in the figure by joining the metal holes and nuts on the bottom cover.
8. Tighten the cable glands.
9. The base part of the Charging Station should be at least 30mm above the ground.

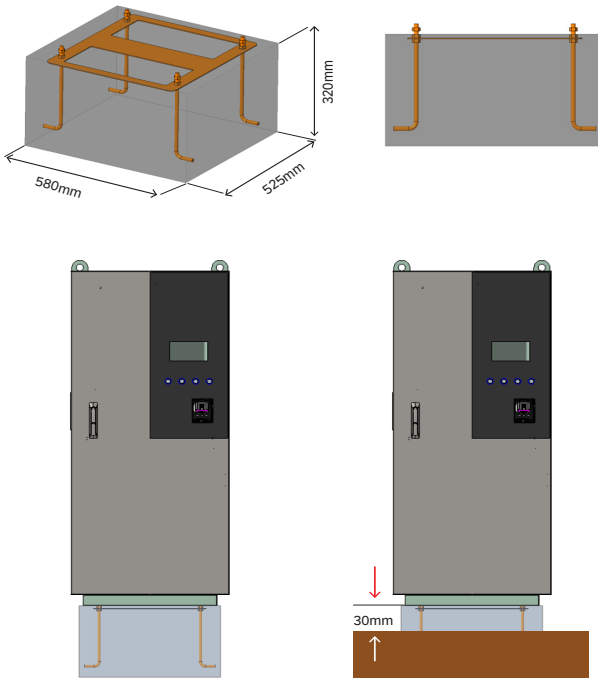

Anchor Plate Dimension:

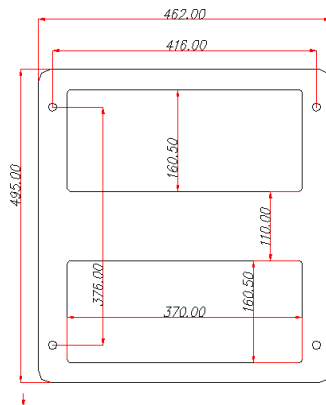

11.4 - OPENING THE FRONT COVERS

Use the key provided to open the front cover.

Pull the handle up slightly. Turn the handle to the right of the charging station at a wide angle.

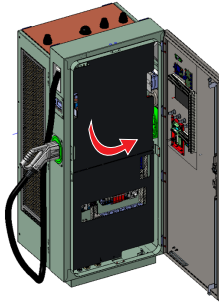

All products images are given for representative purpose only.

1. Insert the cover opening key into the cover lock.
2. Turn the key to the right.
3. After turning the key, pull the cover lock apparatus towards you.
4. Turn the opened cover lock apparatus counterclockwise.
5. This way, the cover will open.

11.5 - CABLE ASSEMBLY

11.5.1 - OPENING THE FRONT COVER AND CABLE CONNECTION

1. Open the front cover of the product with the switches provided by turning the handle counterclockwise at a wide angle.
2. Remove the screws and also the insulation plate covering the AC Mains cable in the lower right corner.

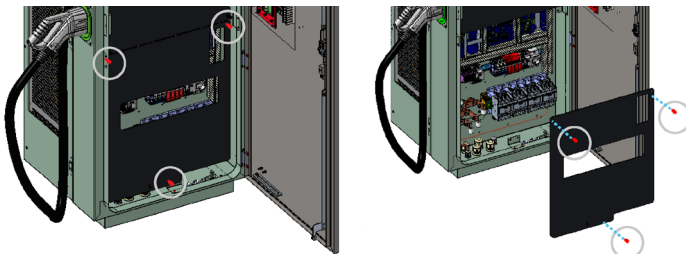

All products images are given for representative purpose only.

Cable lug positions:

All cable lugs (L1, L2, L3, PE and N) must be selected for the wire size shown in the table section 1.5- Protections Required Before System.

This structure is designed to mount cables with low flexibility with cable lugs on the busbar, as shown in the figure. Thus, the midpoints of the cable glands and cable lugs are aligned with the same axis (z-axis), as shown in the figure. Installation should be performed as shown in the figure.

Contact surface of cable gland nuts and cable lugs:

The surface contact of the cable lugs and cable glands is shown in brown in the figure. The mounting surface of the cable lugs corresponds to 92% of the surface data shown in the cable lug data sheet compatible with a cable cross-section.

3. Pass the cables through the cable glands at the bottom of the charging station.
4. Connect the AC Mains cables. First, connect the “PE Line” cable, then the “Line N” cable, and finally the three phase cable (“Line 1”, “Line 2”, “Line 3”) as shown in the figure:

Phase sequence is clockwise.

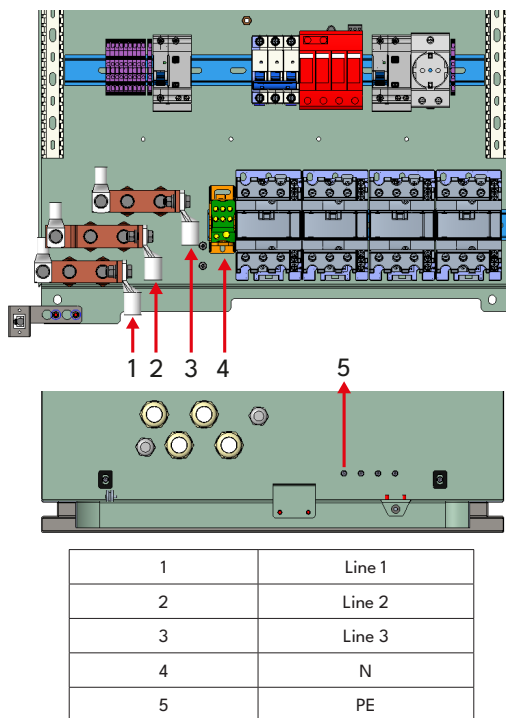

5. Tighten the cable glands with an adjustable wrench. (25Nm)

11.5.2 - SIM CARD CONNECTION (OPTIONAL)

See “Opening the front covers” section and insert the Micro SIM card into the cellular communication module SIM card slot as shown in the figure below.

Ghost OCPP provides the communication between the charging station and the central system via a dedicated APN cellular network. With this system, the manufacturer will have the capability to remotely control any device that has been installed in the field and supported by Ghost OCPP at any time. Thus, controlling the instant status of the products, sending remote commands to the product (restarting the product, diagnostic message), usage data and logs related to the product will be accessible 24/7. With this process, device intervention and controls in the field can be performed quickly/effectively. Within the scope of Ghost OCPP, the manufacturer inserts the SIM card into the Ghost OCPP card and sends it to the field after activating. The management of the Ghost OCPP card is in the charge of the manufacturer.

OCPP Connection GSM Module

Remote monitoring GSM Module

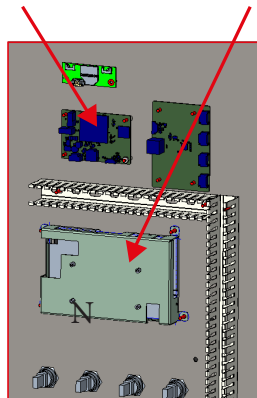

11.6 - COMMISSIONING

11.6.1 - CONNECTING OCPP THROUGH ETHERNET NETWORK

In order to connect your device to the internet over the cable and make the necessary adjustments, you must first prepare the ethernet cable and plug this cable into the locales that should be on the device.

Insert Ethernet cable through the cable gland. Terminate the Ethernet cable with RJ45 terminal and connect the cable to the Ethernet port as shown below.

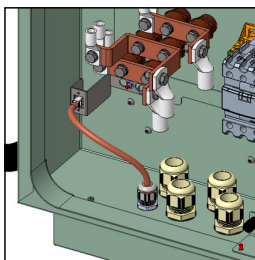

11.6.2 - CONNECTING TO THE SAME NETWORK WITH THE ETHERNET PORT

To access the Web Config User Interface, you need to connect your PC and CV charger to the same ethernet switch or connect the EV charger directly to your PC.

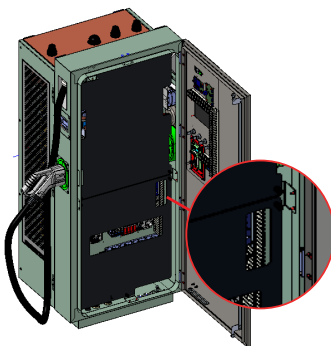

Open the charging station. The default IP address of the HMI card is 192.168.0.10. Therefore, you need to assign a static IP address to your PC, which is on the same network as the HMI card. You should assign a static IP address to your PC on the 192.168.0.0/254 network; The IP address should be between 192.168.0.1 and 192.168.0.254.

For instance, 192.168.0.11 can be assigned to your PC as a static IP.

Press the next button to continue.

11.6.3 - OPENING WEB CONFIGURATION INTERFACE WITH BROWSER

Open your web browser and type 192.168.0.10 which is IP address of HMI board.

You will see login page on your browser;

Each product has a user name and password set as factory configuration.

In this section you can log in to the Web configuration interface by entering the configuration information printed on the label. User Name and Password informations are located on the label pasted to the Quick Start Guide as shown below.

Only for the first login you will be forced to change your password.

You can change password with Change Password Button in WEBUI login page or Administration Password section in the System Maintenance tab.

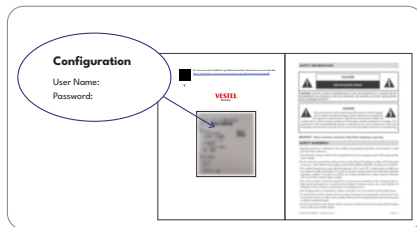

Visuelle Darstellung ist vorhanden

Change Password:

If you click the "Change Password Button" you will be redirected to the Change Password page.

Your password must be minimum 12 maximum 32 character and it contains at least two uppercase letters two lower case letters two number digits and two special characters.

After typing your current password and new password twice, you will be redirected to the login page again to log in with your new password.

CHANGE PASSWORD

Your password must be minimum 12, maximum 32 characters and it contains at least two uppercase letters, two lower case letters, two number digits and two special characters.

User Name:

Current password:

New password:

Confirm new password:

[Back to Login](#)

11.6.4 - WEB CONFIGURATION INTERFACE

You can change the web configuration interface language and log out of the web configuration interface with the buttons in the upper right corner of the page.

MAIN PAGE	<p>The Main page provides an overview of the key system information and connection status of the EVC device. Below are the descriptions of each displayed parameter:</p> <p>CP Serial Number: Unique serial number of the device. It is used for device authentication and remote management.</p> <p>HMI Software Version: The software version of smart board (HMI) that runs the device's touchscreen interface.</p> <p>Power Board Software Version: The version of the software that controls power management and charging operations of device.</p> <p>PLC Software Version: The software version of power line communication board.</p> <p>VCR Software Version: The software version of the VCR (Voltage Current Resistance) board.</p> <p>OCPP Software Version: The version of the Open Charge Point Protocol (OCPP) software, which enables communication with the charging network management system.</p> <p>Duration after Power On: The total time (in hours, minutes, and seconds) that has passed since the device was last powered on. Useful for uptime tracking and performance monitoring.</p> <p>Connection Interface: The current communication method used by device. It can be Ethernet, WLAN (Wi-Fi), or Cellular.</p> <p>OCPP Device ID: Unique identification number used by device when communicating with OCPP server.</p> <p>Connector ID 1 Status: The current status of charging Connector 1 (e.g., Available, Plugged, Charging, Faulted).</p> <p>Connector ID 2 Status: The current status of charging Connector 2 (e.g., Available, Plugged, Charging, Faulted).</p>
------------------	--------------------------------------------------------------------------------------------------------------------------------------------------------------------------------------------------------------------------------------------------------------------------------------------------------------------------------------------------------------------------------------------------------------------------------------------------------------------------------------------------------------------------------------------------------------------------------------------------------------------------------------------------------------------------------------------------------------------------------------------------------------------------------------------------------------------------------------------------------------------------------------------------------------------------------------------------------------------------------------------------------------------------------------------------------------------------------------------------------------------------------------------------------------------------------------------------------------------------------------------------------------------------------------------------------------------------------------------------------------------------------------------------------------------------------------------------------------------------------------------------------------------------------------------------------------------------------------------------------------------------------------------------------------------------------------

11.6.4.1 - GENERAL SETTINGS

Default Interface Languages	HMI display language and web interface language can be selected from the general settings page.
Display Settings	<ul style="list-style-type: none"> • Static - Set brightness/outdoor lighting to a fixed level, options include Low/Medium/High • Sensor Based - Display brightness is changed based on given sensor value thresholds. • Reduced Brightness in Inactive Mode - Sets automatic brightness dimming when the screen is not in use. This option can be enabled or disabled. • Minimum Brightness Value - Defines the minimum brightness for inactive mode. • Show Charge Point ID - Displays the charge point ID on screen (can be enabled/disabled).
Display Logo (Optional)	The user can upload left and right logos to display in the app UI and toggle their visibility using a switch button.
Tilt Threshold	<p>The user can change the tilt threshold in angle. The tilt threshold as an angle is set to 30 for all angles by default.</p> <p>Tilt Threshold Range: 12 - 90</p>
Display QR Code	The user can update the QR Code Settings for each connector on the device. QR Code can be enabled/disabled and if enabled, a limiting value for the QR Code String can be set.
Customer Service Number	You can reach customer service number from WEB UI screen. You can enable or disable it to display on the screen.
Timezone	The user can set the timezone.

11.6.4.2 - OCPP SETTINGS

The required settings for the OCPP connection (activating and deactivating the OCPP connection, entering the connection address, entering the charging station ID, etc.) are made on this page.

Adding a New RFID Card:

In the **Authorization Mode** dropdown menu, select **Authorize with Whitelist** from OCPP Settings tab in the interface. In the **Manage RFID Local List** section, enter the unique ID of the RFID card you want to authorize into the text field.

Once entered, click the **Add** button to include the card into the list. Press the save button to apply the changes.

To apply the update, a **Hard Reset** must be performed. During this process, a confirmation prompt will appear – be sure to confirm the action by selecting **Confirm**.

Once the product restarts, return to the same configuration page and ensure that the newly added card appears in the RFID list.

11.6.4.3 - NETWORK INTERFACES

There are three types of network interfaces in this page; Cellular, Ethernet (LAN), Wi-Fi. Select interfaces' modes as "Enabled" if you want to activate it. You should fill all spaces in suitable formats.

11.6.4.4 - POWER MANAGEMENT

DC Output Configuration	DC Output Configuration(deprecated-will be renamed as Model Code).
Charge Point Maximum Power	Maximum Power value is used to set the maximum output power delivered from charging station.
Fail Safe Power	Fail Safe Power Limiting feature is used to limit the station output power when the OCPP Server connection is lost. When feature is enabled, the user can set output power value. The default value is 10 kW.
Power Module Configurations	DC power sharing enabled option is used to allow CPO to decide if power sharing will be active for power modules. Example: For a 60kW product which has 2 30kW power modules, if DC Power Sharing Enabled is set to True, 2 connectors will be available for charging at maximum of 30kW output. If it is set to False, Then only 1 connector will be available for charging and while one of the connectors is in charging state, other connector status will be set to Unavailable.
Connector Settings	Connector type and corresponding maximum output power is displayed under Connector Settings menu.

11.6.4.5 - SYSTEM MAINTENANCE

Log Files	The logs related to the device can be downloaded from this section.
Firmware Updates	The firmware file of device can be uploaded and upgraded.
Configuration Backup & Restore	The device-related configurations can be backed up and restored from this tab.
System reset	You can proceed to this section to perform Hard Reset and Soft Reset.
Administration Password	The administrator password can be changed from this tab.
Factory Default Configuration	You can reset your device to its factory settings.

11.7 - CLOSING THE COVER

1. Place the (left and right) bottom plates and tighten the bolts. (torque value should be 3 Nm.)
2. Make sure the cables and plugs are not damaged.
3. Insert and tighten the screws of the insulation plate covering the AC Mains cable.

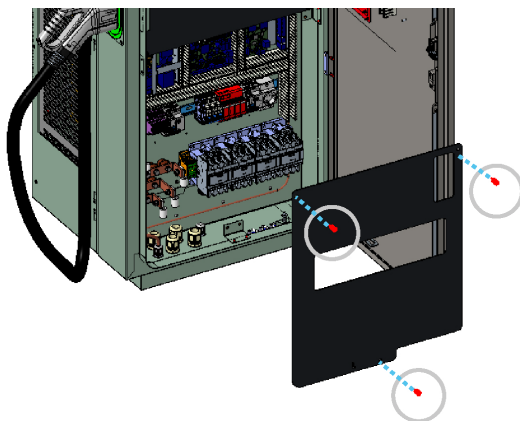

12 - CHECKING THE VALIDITY OF THE MEASUREMENT

Data with transparency software

This section deals with billing, the transmission of legally relevant data and the billing procedure in accordance with the German Measurement and Verification Ordinance (MessEV).

With this charging station, the information on the progressive kWh display is shown on the MID display of the meter, which is approved in accordance with calibration law.

If you have used your RFID card to authorize the charging process, you can request the signed measurement data from the operator of your charging station or your electromobility provider.

If you complete the charging process using your credit card, you will find the invoice amount for the charging process and the link to the receipt server (www.evc.cash) on your credit card statement once the charging process has been completed. You can access the website www.evc.cash via a web browser on your smartphone or computer to download the signed data of the transaction of the loading process by entering the last four credit card digits and the date in the mandatory fields.

To better filter the charging transactions, you can also enter optional fields such as city, country or the ID of the charging station.

Search Receipt

Location:

Select Country ▾

Select City ▾

Chargepoint ID:

Date:

mm/dd/yyyy
🗓

Last Four Digit of the Credit Card

*

*

*

*

SEARCH

What is transparency software?

You can verify digital signatures with transparency software. Depending on its technical design, a charging station generates digitally signed meter readings for each charging process carried out at this charging station. Using these digital signatures, you can check the measured values with a time delay and thus ensure that no one has manipulated your measured values during transmission to your invoice.

If you want to use the transparency software, you must first download it and then open it on your desktop PC.

You can download the transparency software via the following link. The installation is explained on this website.

https://www.safe-ev.de/en/transparency_software.php

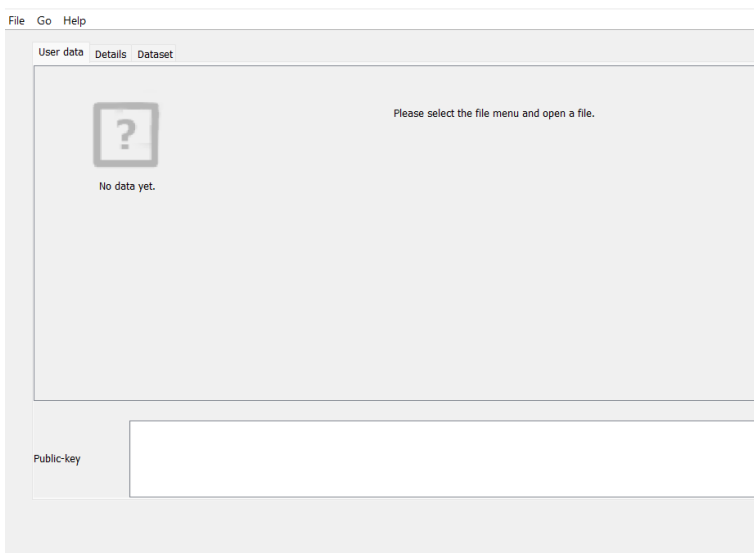

How does the transparency software work?

Transparency software v1.4.1

This software can be used to verify a digital signature. Depending on its technical equipment, a charging station generates a digitally signed meter reading that is linked to the charging station at which an electric vehicle is being charged. With this digital signature, the measured values can be checked with a time delay. As a consumer, you can therefore always be sure that the kWh charged are actually correct and that the measured values can no longer be changed when billing the kWh charged.

LOADING DIGITAL SIGNATURE DATA

Select the meter readings available to you via the “File”/”Open” function and enter the public key of the charging station.

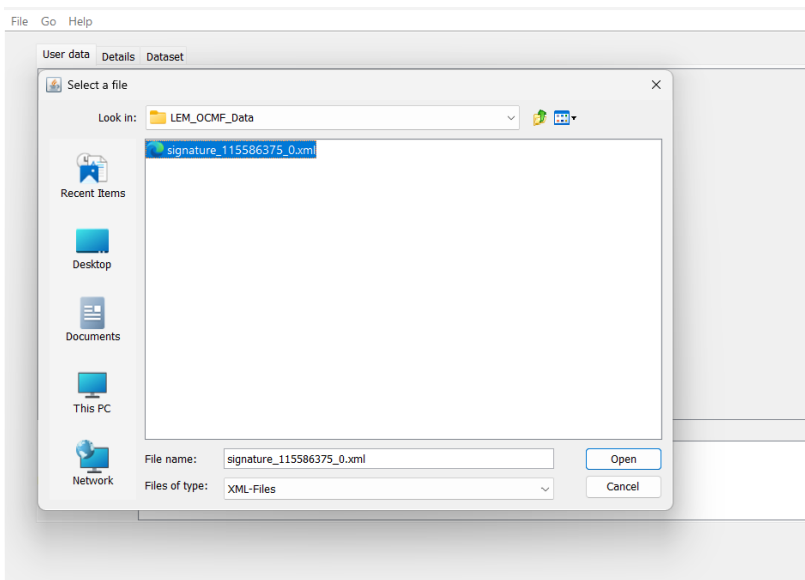

CHECK THE RESULT

Check the result to make sure that the results of the digital signature verification match the information on your invoice or billing document.

File Go Help

User data Details Dataset



Your data has been verified

Meter

Metering value at start of charge transaction
85.027 kWh
24.03.2025 07:07:19 (lokal) (informative)

Metering value at reading moment (end of charge transaction)
113.233 kWh
24.03.2025 07:18:20 (lokal) (informative)

relevant measurement result for charging device utilization time
0h 11m 01s

relevant measurement result for energy output and period of use
28.206 kWh

Public-key

```
3059301306072A8648CE3D020106082A8648CE3D03010703420004446B74D1A4B6C26DDA9C5CD
9F7FFB7FADA5371122EB05FB1D95BD05E128424C55C2D1DD0FEBFCAB4F8F582536C8AE22719A0C
6DB086639BE23FB55BAF14BBD6C9
```

Page 1 of 1

If an incorrect public key is entered, the following error message is displayed.

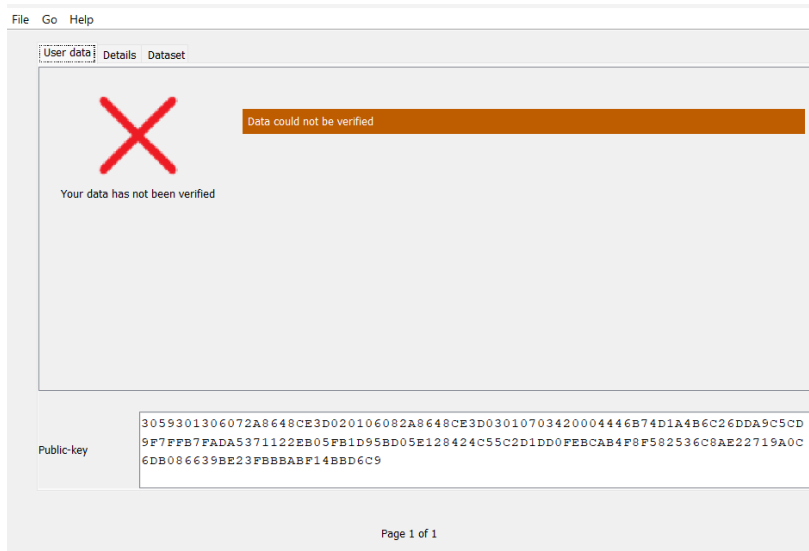

Remote transmission of measurement data to an OCPP backend

The charging station is connected to an OCPP backend and the corresponding signed measurement and log data record is automatically made available to the OCPP backend at the end of a charging process.

Transmission of data records to customers

The transmission of data records to customers is the responsibility of the charging station operator and is not the responsibility of the charging station manufacturer. After the loading process, the signed measurement data records are transferred to a central OCPP system and the end user can access this data via a web interface, email, smartphone app or similar means. The data records are preferably available in .xml format. In the event that you need to verify the charging process data using transparency software, please contact the operator of your charging station or your e-mobility provider to request the signed measurement data.

Verification of the measurement data with the transparency and display software

With the transparency and display software, users can check whether the measurement data originates from a specific charging station and whether its authenticity has been maintained.

The charging station has a public key. The public key is generally accessible and is indicated as a QR code on the type plate of the charging station's measuring unit. The charging station creates a data set with measurement data that is stored in the measuring capsule. The operator of the charging station then creates the invoice based on the signed measurement data record. In

addition to the signed measurement data, the public key must also be provided on the invoice or in a customer portal in a format that is compatible with the transparency and display software.

After receiving the invoice, the consumer can enter the digitally signed measured values together with the public key into the transparency and display software. Verification of the signature gives the consumer the opportunity to check the validity of the measured values. For this purpose, the consumer compares the values shown in the transparency and display software with the invoice contents. Validation of the measurement data record using transparency software ensures that the data record is unaltered and admissible for invoicing.

The transparency and display software checks the following data:

The public key as identifier of the charging station. The public key can also be found on the type plate of the charging station's measuring unit.

Correct measured energy value

Correct user/transaction ID

Checking the signed measurement data set

To check the measurement data set:

1) Download and install a Java runtime environment (this is available for all operating systems and is usually already pre-installed, e.g. Oracle).

2) Download the transparency and display software from
https://www.safe-ev.de/en/transparency_software.php

3) Enter the following data in the transparency and display software:

- the signed measurement data set
- the selection of the "OCMF" format
- the public key of the corresponding charging station

File Go Help

User data Details Dataset

Vendor-Identification	LEM DCBM
Vendor-Version	v1
Pagination of the dataset	T12
Meter-Vendor	LEM
Meter-Serialnumber	1233421204
Meter firmware version	MU-2.3.0.1_SU-0.1.3.0
Identificationmedia status	false
Identificationmedia level	-
Additional Information of identification media	RFID_NONE, OCPP_NONE, ISO15118_NONE, PLMN_NONE
Identificationmedia type	NONE
Identificationmedia data	8C18100C
Single value 1	2025-03-24T07:07:19,000+0000 R 85.027 kWh
Time status at reading 1	relative time based calculation
Single value 2	- 7.591 kWh
Single value 3	2025-03-24T07:18:20,000+0000 R 113.233 kWh
Time status at reading 3	relative time based calculation
Single value 4	- 7.591 kWh

Page 1 of 1

Credit Card:

File Go Help

User data Details Dataset

Vendor-Identification	LEM DCBM
Vendor-Version	v1
Pagination of the dataset	T12
Meter-Vendor	LEM
Meter-Serialnumber	1233421204
Meter firmware version	MU-2.3.0.1_SU-0.1.3.0
Identificationmedia status	false
Identificationmedia level	-
Additional Information of identification media	RFID_NONE, OCPP_NONE, ISO15118_NONE, PLMN_NONE
Identificationmedia type	NONE
Identificationmedia data	1BABD370454617***2025
Single value 1	2025-03-24T07:07:19,000+0000 R 85.027 kWh
Time status at reading 1	relative time based calculation
Single value 2	- 7.591 kWh
Single value 3	2025-03-24T07:18:20,000+0000 R 113.233 kWh
Time status at reading 3	relative time based calculation
Single value 4	- 7.591 kWh

Page 1 of 1

File Go Help

User data Details Dataset

```
OCMF{"FV": "1.0", "GI": "LEM",
DCBM", "GS": "1233421204", "GV": "v1", "PG": "T12", "MV": "LEM", "MS": "1233421204", "MF": "MU-2.3.0
.1_SU-0.1.3.0", "IS": false, "IL": "-", "IF": [{"RFID_NONE", "OCPP_NONE", "ISO15118_NONE", "PLMN_N
ONE"}], "IT": "NONE", "ID": "8C18100C", "CT": "EVSEID", "CI": "murat_test_0.3.0.28_0.0
€/kWh ", "RD": [{"TM": "2025-03-24T07:07:19,000+0000
R", "ZX": "B", "RV": 85.027, "RI": "1-0:1.8.0", "RU": "kWh", "RT": "DC", "EP": "", "ST": "G", "UC": {"UN
": "No_Comp", "UI": 2, "UR": 0}}, {"RV": 7.591, "RI": "1-0:2.8.0", "RU": "kWh", "ST": "G"}, {"ZM": "202
5-03-24T07:18:20,000+0000
R", "ZX": "E", "RV": 113.233, "RI": "1-0:1.8.0", "RU": "kWh", "ST": "G"}, {"RV": 7.591, "RI": "1-0:2.8
.0", "RU": "kWh", "ST": "G"}]} {"SA": "ECDSA-secp256r1-SHA256", "SD": "3045022100B2A426DEE987D6
99CB158B0DC89875125B0C58F3C93AE8E39864795B2674FEE02207F2D00E60DC1C866E303CA92C72125762F
3CF19C218E9A5255C156C19D37884"}
```

Format OCMF

Page 1 of 1

4) Once you have entered the required data, you can start the check.

5) Once this check has been completed, it must be checked whether the results of the signature check match the information on the invoice.

File Go Help

User data Details Dataset

Opened dataset

Transaction ID 35135

Single value 1 (Transaction.Begin)

Single value 1 (Transaction.End)



Your data has been verified

Meter

Metering value at start of charge transaction
29.198 kWh
10.09.2025 07:21:59 (loka) (informative)

29.198 kWh
10.09.2025 07:21:59 (loka) (informative)

Public-key

```
3059301306072A8648CE3D020106082A0648CE3D03010703420004B
BB64FBA73c724BEB2125D311F9AF02267DB85C565F9B33E0401DB01
8689275C1FA3C934085CE57D098454F4965FFB3EB56092A5ECC2F96
FDC095D4DED5780F2
```

Page 1 of 2

All products images are given for representative purpose only.

13 - OVERVIEW OF THE CHARGING STATION WITH DESCRIPTION OF THE MANUFACTURER'S/OPERATOR'S SEALS

13.1 - SEALS OF THE MANUFACTURER

During production, the measuring units of the charger are provided with manufacturer seals. The following illustration shows the images of the EVC16 calibration law product seals. The sections mentioned in rectangular indicate the manufacturer's seal.

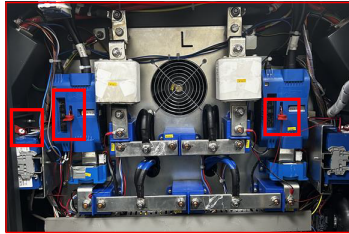

SEAL FOR MID METER

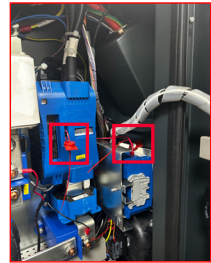
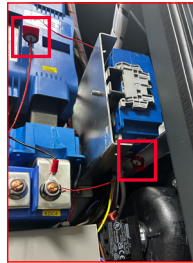
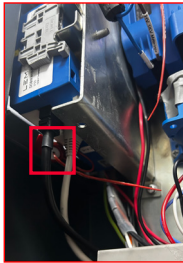
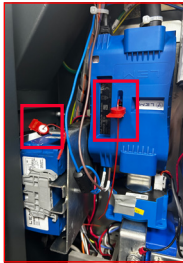

Vorderansicht
der Siegel



Rückseite
der Siegel



13.2 - RECOMMENDED POSITION OF THE OPERATOR SEAL

The recommended place for the operator to seal is as shown in the image below. The parts circled in red indicate the operator's seal. It is recommended to seal the input terminal after the cable is connected to product the during the electric vehicle charger installation.

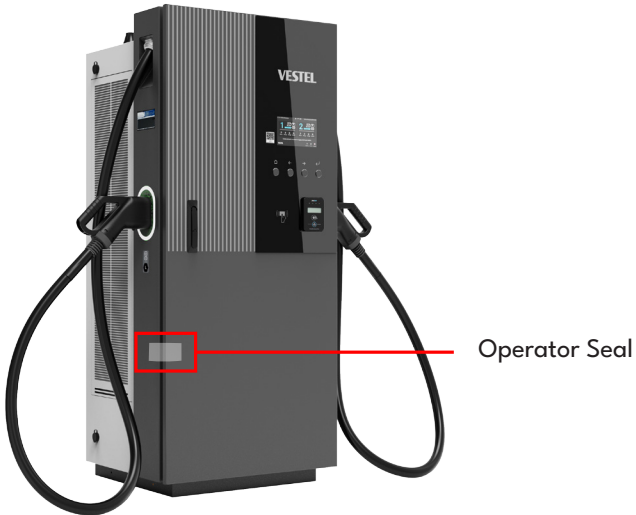

14 - LEGAL INFORMATION

14.1 - MEASUREMENT ACCURACY NOTES ACCORDING TO CSA TYPE EXAMINATION CERTIFICATE

I Requirements for the operator of the charging system, which he must fulfill as a necessary prerequisite for proper operation of the charging system.

The operator of the charging device is the user of the measuring device within the meaning of Section 31 of the Measurement and Verification Act.

1. The charging device is only considered to be used as intended and in compliance with calibration law if the meters installed in it are not exposed to ambient conditions other than those for which their type examination certificate was issued.

2. The charging device is only considered to be used as intended and in compliance with calibration law if only the authentication methods listed under point 1.3.2.3.2 of the currently valid BMP of these 6.8 devices are used.

3. When registering the charging points with the Federal Network Agency, the user of this product must also register the public key specified on the charging device for the charging points in their registration form! Without this registration, it is not possible to operate the column in compliance with calibration law. Weblink:

https://www.bundesnetzagentur.de/DE/Sachgebiete/ElektrizitaetundGas/Unternehmen_Institutionen/E-Mobilitaet/start.html

4. The user of this product must ensure that the calibration validity periods for the components in the charging device and for the charging device itself are not exceeded.

5. The user of this product must ensure that charging devices are taken out of operation promptly if operation in compliance with calibration law is no longer possible due to fault or error indications on the display of the human-machine interface relevant to calibration law. The catalog of fault and error messages in these operating instructions must be observed.

6. The User must store the signed data packets read from the loading device - in accordance with the pagination - permanently and without gaps (also) on hardware dedicated to this purpose in his possession or, by corresponding agreement, in the possession of the EMSP or backend system ("dedicated storage"), - and keep them available for authorized third parties (obligation to operate the storage). Permanent means that the data must be stored not only until the conclusion of the business transaction, but at least until the expiry of any statutory appeal periods for the business transaction. No substitute values may be created for billing purposes for data that is not available.

7. The user of this product shall provide an electronic form of a CSA-approved instruction manual to measurement users who receive and use measurements from this product in the course of their business. The user of this product must pay particular attention to the no. II "Requirements for the user of the measured values from the loading device".

8. The user of this product is subject to the notification obligation in accordance with § 32 MessEG (extract):

§ Section 32 Obligation to notify (1) Anyone using new or renewed measuring devices must notify the competent authority in accordance with federal state law no later than six weeks after commissioning...

9. If deemed necessary by authorized authorities, the meter user must provide the complete content of the dedicated local or backend storage at the EMSP or backend system with all data packets of the billing period.

10. The user of this product must ensure that tariff information shown on the info display of the charging device or an informative display of a payment terminal in the case of spot charging corresponds to the tariff information in the calibrated display and the signed data package.

II Requirements for the user of the measured values from the loading device (EMSP)

The user of the measured values must comply with § 33 of the MessEG:

§ 33 MessEG (quote)

§ 33 Requirements for the use of measured values

(1) Values for measured quantities may not be used in commercial or official dealings or for measurements in the

may only be indicated or used in the public interest if a measuring instrument has been used as intended for their determination and the values are attributable to the respective measurement result, unless otherwise specified in the ordinance pursuant to Section 41 number 2. Other federal regulations that serve comparable protection purposes continue to apply.

(2) Anyone using measured values must ensure, as far as possible, that the measuring device meets the legal requirements and must obtain confirmation from the person using the measuring device that they are fulfilling their obligations.

(3) Anyone who uses measured values must

1. to ensure that invoices, insofar as they are based on measured values, are issued by the person for whom the calculations can be easily reproduced to verify the specified measured values. and
2. to provide suitable aids for the purposes mentioned in number 1 if necessary.

For the user of the measured values, this regulation results in the following specific obligations for the use of measured values in compliance with calibration law:

1. The contract between EMSP and the customer must clearly state that only the supply of electrical energy and not the duration of the charging service is the subject of the contract.
2. The time stamps on the measured values originate from a clock in the charging device that is not certified in accordance with measurement and calibration law. They may therefore not be used to calculate a tariff for the measured values.
3. The EMSP must ensure that the customer is automatically sent a receipt of the measurement and the details for determining the transaction after completion of the measurement and at the latest at the time of invoicing, unless the customer expressly waives this. The details for determining the transaction can be as follows:
 - a. Name of the EMSP
 - b. Start and end time of the charging process
 - c. Charged energy in kWh
 - d. Credit card number

4. If the customer requests proof of the correct transfer of the measurement results from the charging device to the invoice, the user of the measured values is obliged to provide proof in accordance with MessEG, § 33, para. (3) is obliged to provide this. If the customer requests a trustworthy permanent proof in accordance with Annex 2 10.2 MessEV, the user of the measured values is obliged to supply it to him. The EMSP shall inform its customers of these obligations in an appropriate form.

This can be done in the following ways, for example, depending on the authentication method:

- a. When charging with a continuing obligation via the textual contract
- b. For ad hoc charging using a (contactless) debit card together with the receipt via a short link in the purpose of use in the account statement

5. The EMSP must provide the customer with the billing-relevant data packages automatically after completion of metering and at the latest at the time of invoicing, including signature, as a data file in such a way that they can be checked for falsification using the transparency and display software. The data packets can be made available via channels that are not verified under calibration law in the following ways and depending on the authentication method:

- a. When loading with a continuing obligation via e-mail or access to a backend system
- b. In the case of ad hoc charging by means of a (contactless) debit card via a short link in the purpose of use in the account statement and associated access to a retrieval platform on which the information mentioned under point 3 is requested to determine the transaction, so that the customer receives the permanent proof. Only information that can also be found on the customer's account statement may be requested to determine the transaction.

In addition, the EMSP must provide the customer with the transparency and display software belonging to the charging device to check the data packets for falsification. This can be done by referring to the source of supply in the operating instructions for the customer or through the channels mentioned above.

6. The EMSP must be able to show in a verifiable manner which means of identification was used to initiate the charging process associated with a specific measured value. This means that he must be able to prove that he has correctly assigned the personal identification data to each business transaction and invoiced measured value. The EMSP shall inform its customers of this obligation in an appropriate form.

7. The EMSP may only use values for billing purposes for which data packets are available in any existing dedicated memory in the charging device and or the memory at the EMSP or backend system. Substitute values may not be created for accounting purposes.

8. The EMSP must make appropriate agreements with the operator of the charging facility to ensure that the data packets used for billing purposes are stored for a sufficient period of time to complete the associated business transactions.

9. The EMSP shall enable the authentication of the copies of the product belonging to these operating instructions used by it by providing suitable means of identification in the event of a justified request for the purpose of carrying out calibrations, diagnostic tests and usage monitoring measures.

10. All of the aforementioned obligations apply to the EMSP as a user of measured values within the meaning of

§ 33 MessEG even if it obtains the measured values from the charging facilities via a roaming service provider.

15 - MAINTENANCE

The device is maintenance-free. The deadlines for the validity of the calibration must be observed for the electricity meter and the charging station.

Conformity with the points listed in the chapters “Model description”, “Technical specifications” and “Legal information” must be guaranteed over the entire service life of the product. The user must not exceed the validity period for the calibration of the meter and the charging stations. If the calibration period is exceeded, please contact the manufacturer so that an authorized technical service company can replace the measuring device in the charging station.

16 - PERIODIC MAINTENANCE LIST

	Maintenance Period (year)									
	1	2	3	4	5	6	7	8	9	10
Air filters	R	R	R	R	R	R	R	R	R	R
Plugs	I	I	I	I	I	I	I	I	I	I
Display	C	C	C	C	C	C	C	C	C	C
Distribution elements (RCBO)	T	T	T	T	T	T	T	T	T	T
AC input terminals	T	T	T	T	T	T	T	T	T	T
DC relay terminals	T	T	T	T	T	T	T	T	T	T
DC output cable and terminals	T	T	T	T	T	T	T	T	T	T
Fan	I	I	I	I	I	I	I	I	I	I
Body	C	C	C	C	C	C	C	C	C	C
Grounding resistance	M	M	M	M	M	M	M	M	M	M

C : Clean

I : Inspect (check, approve, clean, tighten or replace if necessary)

M : Measure

T : Tighten

R : Review

Air filters

Air filters should be replaced every year when going for maintenance.

Plugs

All spark plugs should be checked when going for maintenance. If the plug is broken or cracked, it should be replaced. Furthermore, a charging test should be performed with all Plugs.

Display

During maintenance, the screen should be checked using the physical buttons, as the screen is non-touch. All functions can be controlled through these buttons. If there is no issue with the button operations, the screen should be cleaned.

Distribution elements (RCBO)

Distribution elements (RCBO) should be checked and tightened when going for maintenance. These elements can be tightened with a screwdriver with a torque of 2 Nm.

AC input terminals

The AC input terminals should be checked and tightened when going for maintenance. These terminals should be tightened with a torque of 8 Nm for metric 8 bolts and 10 Nm for metric 10 bolts.

DC relay terminals

DC relay ends should be checked when going for maintenance. Tightening process should be performed with 6.5 Nm.

DC output cable and terminals

DC output cable and terminals should be checked when going for maintenance. They should be checked for any damage.

Fan

Fans should be checked when going for maintenance. In case of any breakage or damage, the damaged fan must be replaced. If there is no problem with the fans, a charging attempt should be made. It should be checked whether the fans rotate during this charging.

Body

The outer cabinet should be cleaned when going for maintenance.

Grounding resistance

A mechanism for measuring with a megger should be installed when going for maintenance. After the piles are driven, the voltage between the two piles should be less than 1V.

In cases where product transportation is required

During lifting, it is necessary to use 2 ropes of min 540mm (in case of using a single rope of L min=1080mm, the rope must be fixed from the middle lifting part).

During lifting, there should be a minimum angle of 60 degrees at both rope ends as shown in the image. Using a shorter sling will cause damage to the product.

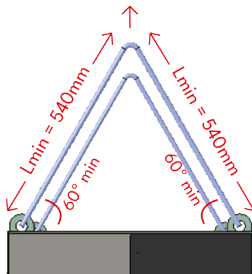

17 - WIRELESS LAN TRANSMITTER SPECIFICATIONS

Frequency Ranges	Max Output Power
2400 - 2483,5 MHz (CH1 - CH13)	< 100 mW
5150 - 5250 MHz (CH36 - CH48)	< 200 mW (*)
5250 - 5350 MHz (CH52 - CH64)	< 200 mW (*)
5470 - 5725 MHz (CH100 - CH140)	< 200 mW (*)

(*) '< 100 mW' for the Ukraine

Country Restrictions

This Wireless LAN equipment is intended for home and office use in all EU countries, the UK and Northern Ireland (and other countries following the relevant EU and/or UK directive). The 5.15 – 5.35 GHz band is restrictions indoor operations only in all EU countries, the UK and Northern Ireland (and other countries following the relevant EU and/or UK directive). Public use is subject to general authorisation by the respective service provider.

Country	Restriction
Russian Federation	Indoor use only
Israel	5 GHz band only for 5180 MHz-5320 MHz range

The requirements for any country may change at any time. It's recommended that user checks with local authorities for the current status of their national regulations for both 2.4 GHz and 5 GHz wireless LANs.

Hereby, Vestel Mobilite SAN. VE TİC. A.Ş., declares that the radio equipment type EVC is in compliance with Directive 2014/53/EU and Radio Equipment Regulations 2017. The full text of the EU declaration of conformity is available at the following address: doc.vosshub.com.

VESTEL

MOBILITY



Hersteller: VESTEL MOBİLİTE SANAYİ VE TİCARET A.Ş. EGE SERBEST BÖLGE ŞUBESİ
Zafer SB Mah. Ayfer sok. No:22 İç Kapı No:1 Gaziemir, İZMİR/TÜRKİYE

Distributor: VESTEL HOLLAND B.V. GERMANY BRANCH OFFICE
Parkring 6, 85748 Garching b. München/Germany

Telefon: +49 89 55295-0

Fax: +49 89 55295-5086

Mail: EVC@Vestel-Germany.de

Web: www.Vestel-echarger.com

Im Service-oder Garantiefall kontaktieren Sie uns bitte über:

Telefon: 089 211 29 999 (Deutschland)

0800 29 78 52 (Österreich)

E-Mail: service.evc@vestel-germany.de (alle Länder)

Unsere Garantiebedingungen für EV-Charger finden Sie unter:

<http://vestel-germany.de/de/page/service>