



ELECTRIC VEHICLE CHARGER EVC08 LIVEO SERIES

Installation Guideline



CONTENTS

1 - SAFETY INFORMATION	3
1.1 - SAFETY WARNINGS	3
1.2 - GROUND CONNECTION WARNINGS	4
1.3 - POWER CABLES, PLUGS AND CHARGING CABLE WARNINGS	4
1.4 - WALL MOUNTING WARNINGS	4
2 - DESCRIPTION	5
3 - GENERAL INFORMATION	6
3.1 - INTRODUCTION OF THE PRODUCT COMPONENTS	6
3.2 - DIMENSIONAL DRAWINGS	7
4 - REQUIRED EQUIPMENT, TOOLS AND ACCESSORIES	8
5 - TECHNICAL SPECIFICATION	9
6 - CONNECTIVITY	9
7 - OTHER FEATURES (CONNECTED MODELS)	10
8 - AUTHORIZATION	10
9 - MECHANICAL SPECIFICATIONS	10
10 - ENVIRONMENTAL TECHNICAL SPECIFICATIONS	10
11 - INSTALLING CHARGING STATION	11
11.1 - SUPPLIED INSTALLATION EQUIPMENT AND ACCESSORIES	11
11.2 - PRODUCT INSTALLATION STEPS	12
11.2.1 - WALL MOUNT INSTALLATION	12
11.2.2 - SINGLE PHASE CHARGING STATION AC MAINS CONNECTION	14
11.2.3 - THREE PHASE CHARGING STATION AC MAINS CONNECTION	15
12 - DATA CABLE CONNECTION TABLE	16
13 - TERMINAL BOARD CONNECTIONS AND SETTINGS	17
13.1 - EXTERNAL ENABLE INPUT FUNCTIONALITY	18
13.2 - POWER OPTIMIZER (REQUIRES OPTIONAL ACCESSORIES)	18
13.2.1 - POWER OPTIMIZER WITH EXTERNAL MID METER	19
13.2.2 - POWER OPTIMIZER WITH EXTERNAL CURRENT TRANSFORMER (CT) (OPTIONAL)	20
13.3 - LOAD SHEDDING	21
14 - FACTORY RESET	21
15 - COMMISSIONING & OCPP CONNECTION	22
15.1 - CONNECT OCPP OVER CELLULAR NETWORK (OPTIONAL)	22
15.2 - COMMISSIONING	22
15.2.1 - CONNECT PC TO THE SAME NETWORK WITH SMART BOARD	22
15.2.2 - OPENING WEB CONFIGURATION INTERFACE VIA WI-FI HOTSPOT	22
15.2.3 - OPENING WEB CONFIGURATION INTERFACE WITH BROWSER	23
16 - WEB CONFIGURATION INTERFACE	24
16.1 - GENERAL SETTINGS	25
16.2.1 - FOLLOW THE SUN	29

16.2.1.1 - INVERTER TYPE AND MODE CONFIGURATIONS WITH DIFFERENT MEASUREMENT METHODS	29
16.2.1.1.1 - EXPORT MODE WITH THE USAGE OF CTS	29
16.2.1.1.2 - EXPORT MODE WITH THE USAGE OF UTILITY METER	30
16.2.1.2 - MODES OF OPERATION	31
16.2.1.2.1 - SUN ONLY	31
16.2.1.2.2 - SUN HYBRID	31
16.2.1.2.3 - MAX HYBRID	31
16.2.1.3 - AUTO PHASE SWITCHING	31
16.7 - LOCAL LOAD MANAGEMENT OF THE DEVICE	36
16.7.1 - MODBUS TCP/IP PROTOCOL PARAMETERS	36
16.7.2 - STATIC MANAGEMENT	36
16.7.3 - DYNAMIC MANAGEMENT	37
16.7.4 - STAR TOPOLOGY	37
16.7.4.1 - Static Supply Star Topology	38
16.7.4.2 - Dynamic Supply Star Topology	38
16.7.5 - CONFIGURATION OF CHARGE POINT ROLES	39
16.7.5.1 - CONFIGURATION OF SLAVE CHARGING STATIONS	39
16.7.5.2 - EQUALLY SHARED	40
16.7.5.3 - FIFO (FIRST IN - FIRST OUT)	41
16.7.5.4 - COMBINED LOAD MANAGEMENT	41
17 - UK REGULATION CHANGES ACCORDING TO SMART CHARGING (OPTIONAL)	44

1 - SAFETY INFORMATION



CAUTION
RISK OF ELECTRIC SHOCK



CAUTION: ELECTRIC VEHICLE CHARGER DEVICE SHALL BE MOUNTED BY A LICENSED OR AN EXPERIENCED ELECTRICIAN AS PER ANY REGIONAL OR NATIONAL ELECTRIC REGULATIONS AND STANDARDS IN EFFECT.



CAUTION

AC grid connection and load planning of the electric vehicle charging device shall be reviewed and approved by authorities as specified by the regional or national electric regulations and standards in effect.



For multiple electric vehicle charger installations the load plan shall be established accordingly. The manufacturer shall not be held liable directly or indirectly for any reason whatsoever in the event of damages and risks that are borne of errors due to AC grid supply connection or load planning.

IMPORTANT - Please read these instructions fully before installing or operating

1.1 - SAFETY WARNINGS

- Keep this manual in a safe place. These safety and operating instructions must be kept in a safe place for future reference.
- Check that the voltage marked on the rating label and do not use charging station without appropriate mains voltage.
- Do not continue to operate the unit if you are in any doubt about it working normally, or if it is damaged in any way - switch off the mains supply circuit breakers (MCB and RCCB). Consult your local dealer.
- The ambient temperature range should be between -25°C and $+50^{\circ}\text{C}$ without direct sunlight and at a relative humidity of between 5 % and 95 %. Use the charging station only within these specified operating condition.
- The device location should be selected to avoid excessive heating of the charging station. High operating temperature caused by direct sunlight or heating sources, may cause reduction of charging current or temporary interruption of charging process.
- The charging station is intended for outdoor and indoor use. It can also be used in public places.
- To reduce the risk of fire, electric shock or product damage, do not expose this unit to severe rain, snow, electrical storm or other severe weathers. Moreover, the charging station shall not be exposed to spilled or splashed liquids.
- Do not touch end terminals, electric vehicle connector and other hazardous live parts of the charging station with sharp metallic objects.
- Avoid exposure to heat sources and place the unit away from flammable, explosive, harsh, or combustible materials, chemicals, or vapors.
- Risk of Explosion. This equipment has internal arcing or sparking parts which should not be exposed to flammable vapors. It should not be located in a recessed area or below floor level.

- This device is intended only for charging vehicles not requiring ventilation during charging.
- To prevent risk of explosion and electric shock, ensure that the specified Circuit Breaker and RCD are connected to building grid.
- The lowest part of the socket-outlet shall be located at a height between 0,5 m and 1,5 m above ground level.
- Adaptors or conversion adapters are not allowed to be used. Cable extension sets are not allowed to be used.



WARNING: Never let people (including children) with reduced physical, sensory or mental capabilities or lack of experience and or knowledge use electrical devices unsupervised.



CAUTION: This vehicle charger unit is intended only for charging electric vehicles not requiring ventilation during charging.

1.2 - GROUND CONNECTION WARNINGS

- Charging station must be connected to a centrally grounded system. The ground conductor entering the charging station must be connected to the equipment grounding lug inside the charger. This should be run with circuit conductors and connected to the equipment grounding bar or lead on the charging station. Connections to the charging station are the responsibility of the installer and purchaser.
- To reduce the risk of electrical shock, connect only to properly grounded outlets.
- **WARNING :** Make sure that during installing and using, the charging station is constantly and properly grounded.

1.3 - POWER CABLES, PLUGS and CHARGING CABLE WARNINGS

- Be sure that charging cable is Type 2 socket compatible on charging station side.
- A damaged charging cable can cause fire or give you an electric shock. Do not use this product if the flexible Charging cable or vehicle cable is frayed, has broken insulation, or shows any other signs of damage.
- Ensure that the charge cable is well positioned thus; it will not be stepped on, tripped over, or subjected to damage or stress.
- Do not forcefully pull the charge cable or damage it with sharp objects.
- Never touch the power cable/plug or vehicle cable with wet hands as this could cause a short circuit or electric shock.
- To avoid a risk of fire or electric shock, do not use this device with an extension cable. If the mains cable or vehicle cable is damaged it must be replaced by the manufacturer, its service agent, or similarly qualified persons in order to avoid a hazard.

1.4 - WALL MOUNTING WARNINGS

- Read the instructions before mounting your charging station on the wall.
- Do not install the charging station on a ceiling or inclined wall.
- Use the specified wall mounting screws and other accessories.
- This unit is rated for indoor or outdoor installation. If this unit is mounted outdoors, the hardware for connecting the conduits to the unit must be rated for outdoor installation and be installed properly to maintain the proper IP rating on the unit.

2 - DESCRIPTION

<p>Model Name</p>	<p><u>MODEL DESCRIPTION: EVC08*-AC***-*</u></p> <p>EVC08 : Electric Vehicle AC Charger</p> <p>1st Asterisk (*) : Cabinet Type</p> <p>01 : Liveo</p> <p>02 : Newnow</p> <p>2nd Asterisk (*) : Rated Power</p> <p>7 : 7.4 kW (1Phase Supply Equipment)</p> <p>11 : 11 kW (3Phase Supply Equipment)</p> <p>22 : 22 kW (3Phase Supply Equipment)</p> <p>3rd Asterisk (*) can include combinations of the following communication module options. High Secure Smart Board with Ethernet Port, Wi-Fi, RFID and NFC reader are standard equipment for all of the model variants. L and 5G options cannot be selected simultaneously.</p> <p>L : LTE / 3G / 2G module</p> <p>5G : 5G / LTE / 3G module</p> <p>P : ISO 15118 PLC module</p> <p>4th Asterisk (*) can be one of the following:</p> <p>Blank : No Display</p> <p>D : 4.3" TFT color display</p> <p>5th Asterisk (*) can be one of the following:</p> <p>Blank : No MID</p> <p>MID : Charging unit with MID meter.</p> <p>EICH : Charging Unit with Eichrecht Conformity</p> <p>6th Asterisk (*) can be one of the following:</p> <p>Blank : Case-B Connection with normal socket</p> <p>T2S : Case-B Connection with shuttered socket</p> <p>T2P : Case C Connection with Type-2 plug</p> <p>T1P : Case C Connection with Type-1 plug</p>
<p>Cabinet</p>	<p>EVC08</p>

3 - GENERAL INFORMATION

3.1 - INTRODUCTION OF THE PRODUCT COMPONENTS

Socket Equipped Models

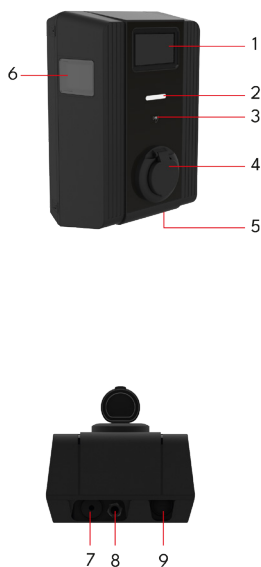

EN Socket Models

- 1- Information Display (optional)
- 2- Status indicator LED
- 3- RFID Card Reader
- 4- Socket Outlet
- 5- Product Label
- 6- MID Meter
- 7- Charging station connection cable union nut
- 8- Charging station Ethernet connection cable gland nut
- 9- Out of use

Tethered Cable Models









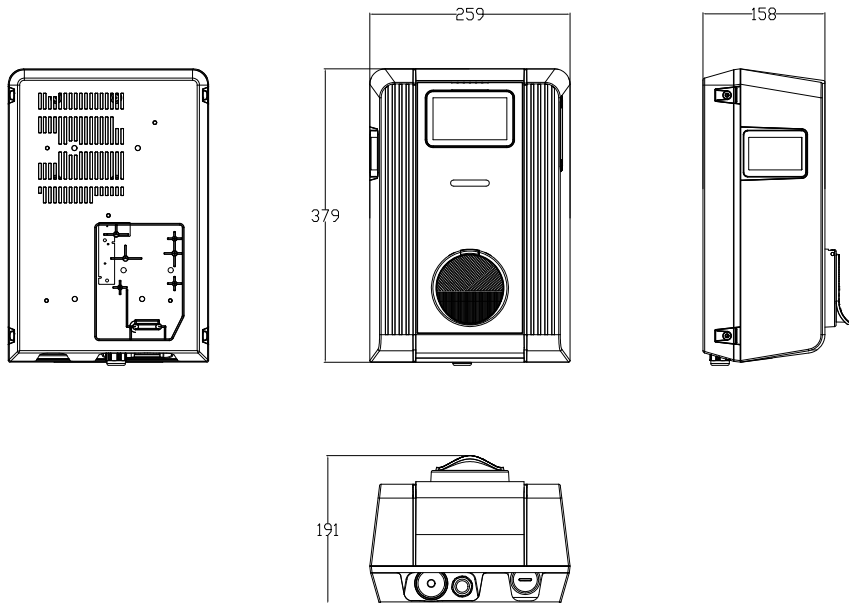



EN Tethered Cable Models

- 1- Information Display (optional)
- 2- Status indicator LED
- 3- RFID Card Reader
- 4- Product Label
- 5- AC Plug Holder (optional)
- 6- Charging Plug
- 7- MID Meter
- 8- Charging station connection cable union nut
- 9- Charging station Ethernet connection cable gland nut
- 10- Charging cable

3.2 - DIMENSIONAL DRAWINGS



4 - REQUIRED EQUIPMENT, TOOLS and ACCESSORIES

		
Drill Bit 8mm	Impact Drill	PC or Mobile Phone
		
Volt Indicator	Torx T25 Security Screwdriver	Flathead Screwdriver (Tip width 2.00-2.5 mm)
		
Right Angle Screwdriver Adapter / Torx T20 Security Bit	Pointed Spudger	RJ45 Crimping Tool
		
Cat5e or cat6 ethernet cable		

5 - TECHNICAL SPECIFICATION

This product is compliant to IEC61851-1 (Ed3.0) and IEC61851-21-2 standard for Mode 3 use.

Model	EVC08-AC22 Series	EVC08-AC11 Series	EVC08-AC7 Series
IEC Protection class	Class - I		
Vehicle Interface	Socket Model	Socket TYPE 2 (IEC 62196)	
	Cable Model	Cable with TYPE 2 (IEC 62196) Female Plug	
Voltage and Current Rates	230/400V ~ 50 Hz - 3-Phase 32A	230/400V ~ 50 Hz - 3-Phase 16A	230 V ~ 50 Hz - 1-Phase 32A
Broken PEN Detection Voltage Range (Optional)	<208V , >254V Single/Three phase TN-C-S supplies only		
AC Maximum Charge Output	22kW	11kW	7.4kW
Built-in Residual Current Sensing module	6mA DC 4P- 40mA AC RCCB Type-A		
Required Circuit Breaker on AC Mains	4P-40A MCB Type-C	4P-20A MCB Type-C	2P-40A MCB Type-C
Required AC Mains Cable	5 x 6 mm ² (< 50 m) External Dimensions: Ø 18-25 mm	5 x 4 mm ² (< 50 m) External Dimensions: Ø 18-25 mm	3 x 6 mm ² (< 50 m) External Dimensions: Ø 13-18 mm
Required AC Mains Cable (Optionally only for France)	5 x 10 mm ² (< 50 m) External Dimensions: Ø 18-25 mm	5 x 6 mm ² (< 50 m) External Dimensions: Ø 18-25 mm	3 x 10 mm ² (< 50 m) External Dimensions: Ø 13-18 mm

6 - CONNECTIVITY

Ethernet	10/100 Mbps Ethernet
Wi-Fi	Wi-Fi 802.11 a/b/g/n/ac 2.4 GHz and 5 GHz
Bluetooth (Optional)	5.1 and 4.2 (low energy)
Cellular (Optional)	LTE / 3G / 2G LTE: B1 (2100 MHz), B3 (1800 MHz), B7 (2600 MHz), B8 (900 MHz), B20 (800 MHz), B28A (700 MHz) WCDMA: B1 (2100 MHz), B8 (900 MHz) GSM: B3 (1800 MHz), B8 (900 MHz)

7 - OTHER FEATURES (CONNECTED MODELS)

Diagnostics	Diagnostics over OCPP WebconfigUI
Software Update	Remote software update over OCPP WebconfigUI update Remote software update with server

8 - AUTHORIZATION

RFID	ISO-14443A/B and ISO-15693
PLUG & CHARGE (Optional)	ISO-15118-2

9 - MECHANICAL SPECIFICATIONS

















Material	Plastic
Product size	260 mm (Width) x 350 mm (Height) x 158 mm (Depth-cable model), 191 mm (Depth-socket model)
Dimensions (with package)	365 mm (Width) x 495 mm (Height) x 320 mm (Depth) - (cable model) 365 mm x 495 mm x 295 mm - (socket model)
Product weight	5,5 kg for socket equipped model 9 kg for tethered cable model (3 phase) 7,5 kg for tethered cable model (1 phase)
Weight with package	7,6 kg for socket equipped model 12 kg for tethered cable model (3 phase) 10,5 kg for tethered cable model (1 phase)
AC Mains Cable Dimensions	For three-phase models Ø 18-25 mm For one-phase models Ø 13-18 mm
Cable Inlets	AC Mains / Ethernet / Modbus

10 - ENVIRONMENTAL TECHNICAL SPECIFICATIONS

Protection Class	Ingress Protection	IP54
	Impact Protection	IK10
Usage Conditions	Temperature	-25 °C to 50 °C
	Humidity	5% - 95% (relative humidity, without condensation)
	Altitude	0 - 3,000m

11 - INSTALLING CHARGING STATION

11.1 - SUPPLIED INSTALLATION EQUIPMENT AND ACCESSORIES

Accessory/Material Name	Use For	Quantity	Picture
Mounting Plate	Mounting the unit to the wall or metal pole	1	
Mounting Cover	Protects mounting points and connections after installation.	1	
Dowels (M8x50 Plastic Dowels)	Mounting charging station to the wall	7	
Torx T25 Security Screw (6x50)	Mounting charging station to the wall	7	
Torx T20 Security L-Allen	IP for screws which are used for mounting charging station to the Wall.	1	
RJ45 Male Connector (optional)	LAN Cable connection	1	
Ferrite	Inserted onto the ethernet cable	2	
Ferrite	Inserted onto the AC mains cable	1	
AC Cable Holder	Holding AC mains cable in place	1	
Cable Gland	Cable gland for AC mains cables	1	
Plastic Screw (5x20)	Fixing internal components	2	
AC Plug Holder (optional)	This part is mounted on the wall or stand pole so that the cable is wound over it.	1	
SIM Card (optional)	Product control with internet connection	1	
User RFID Card (optional)	Start&Stop Charging	2	
Master RFID Card (optional)	Adding & Removing the User RFID Cards to Local RFID List	1	
QSG	Quick Start Guide	1	

11.2 - PRODUCT INSTALLATION STEPS

CAUTION!

- Ensure that ground resistance of the installation less than 60ohms.
- Prior to mounting your charging station on the wall, read these instructions.
- Do not mount your charging station to the ceiling or an inclined wall.
- Use the wall mounting screws and other accessories specified.
- This charging station is classified as indoor and outdoor installation compatible. If the device is installed outside the building, the hardware that will be used to connect the cables to the charger shall be compatible with outdoor use and the charging station shall be mounted preserving the IP rate of the charger.

11.2.1 - WALL MOUNT INSTALLATION

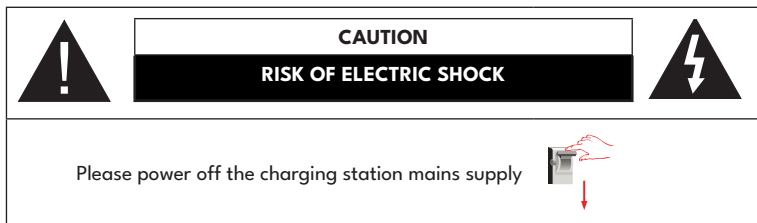

Wall mount installation is common for all charging station models.

- 1-** Remove 4 screws (2 on right, 2 on left side of the charger) of the mounting plate of the charger with torx T20 security L-Allen or screwdriver adapter using torx T20 security bit.
- 2-** Place the mounting plate of the charging station to the wall and mark the drill bit holes with a pencil.
- 3-** Drill the wall on the marked points using the impact drill (8mm drill bit). Place the dowels into the holes.
- 4-** Tighten the security screws (6x50) of the mounting plate using torx T25 screwdriver.
- 5-** Insert the AC mains cable into the mounting plate from the left cable gland which below the mounting plate. Follow the "AC Mains Connection Instructions" on the next pages, depending on the model of the charger. (Single/Three Phase)
- 6-** Place the charging station into the mounting plate and tighten the 4 screws (2 on right, 2 on left side of the charger) with Torx T20 security L-Allen or screwdriver adapter using torx T20 security bit. (Min:1.2Nm; Max:1.8Nm)
- 7-** Mounting the charging station on the wall is finished.

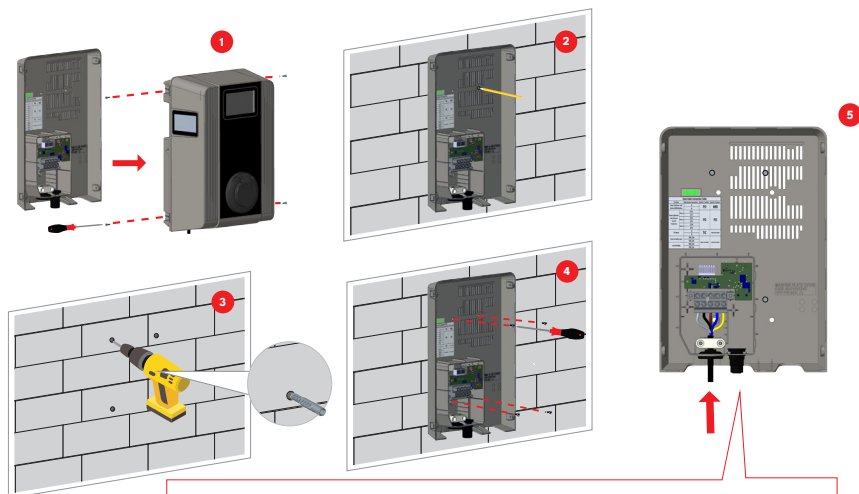

Please check the below instructions for details of Single Phase or Three Phase cable connections.

Before closing the cover of the charging station, check next instructions if any function related to these sections are used.

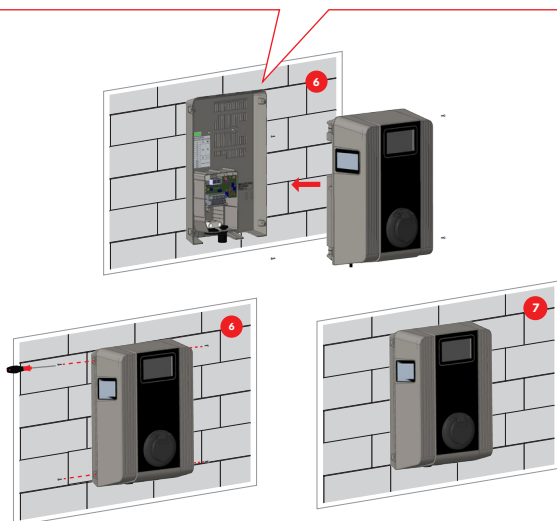

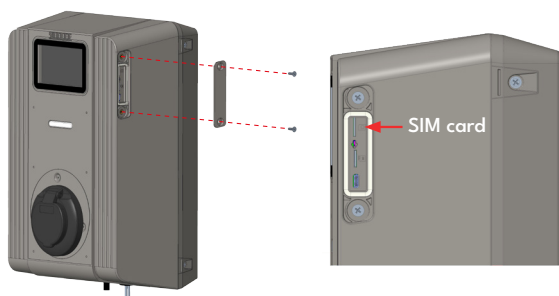

SIM card, Type C USB and SD card slots are placed under the service cover of the charger. Service cover is fixed with secure screws which can only be removed torx T20 security L-Allen or screwdriver adapter using torx T20 security bit.

11.2.2 - SINGLE PHASE CHARGING STATION AC MAINS CONNECTION

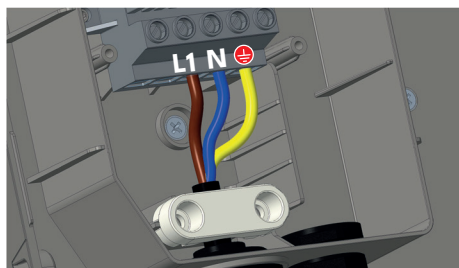

- 1-** Insert the cables to the terminal block as shown in the image. Check the table below to match Electric Terminal number with AC Cable Color.
- 2-** Tighten the screws on the terminal block as shown in the image with the tightening torque of 2 Nm.

Electric Terminal	AC Cable Color
L1	AC L1 (Brown)
N	AC Neutral (Blue)
	Earth (Green-Yellow)

For single phase **IT Grid** installation, wiring diagram which is shown below should be used. Also grounding type should be set to "IT Grid" from the "Installation settings" menu in web user interface.

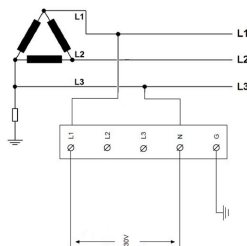

11.2.3 - THREE PHASE CHARGING STATION AC MAINS CONNECTION

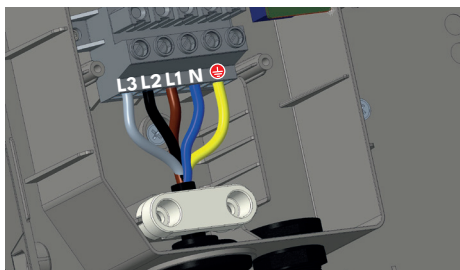

- 1- Insert the cables to the terminal block as shown in the image. Check the table below to match Electric Terminal number with AC Cable Color.
- 2- Tighten the screws on the terminal block as shown in the image with the tightening torque of 2Nm.

Electric Terminal	AC Cable Color
L3	AC L3 (Grey)
L2	AC L2 (Black)
L1	AC L1 (Brown)
N	AC Neutral (Blue)
⊕	Earth (Green-Yellow)

If you want to install the three-phase charging station in single-phase, the phase cable connection must be made on terminal L1 as shown in the figure in the SINGLE-PHASE CHARGING STATION AC MAINS CONNECTION section.

12 - DATA CABLE CONNECTION TABLE

Function		Data Socket Connections	Switch 1 Position	Switch 2 Position
Power Optimizer with External MID Modbus		A	PO	MID
		B		
Power Optimizer with External Current Trasformer	Phase 1	CT1+	PO	PO
		CT1-		
	Phase 2	CT2+		
		CT2-		
	Phase 3	CT3+		
		CT3-		
TIC Meter		I1	TIC	PO
		I2		
External Inable Input		EN1_IN+	does not matter	does not matter
		EN1_IN-		
Load Shedding		EN2_IN+		
		EN2_IN-		

13 - TERMINAL BOARD CONNECTIONS AND SETTINGS

- 1- Remove rubber cork from cable gland.
- 2- Insert cable through the cable holes. One hole is for ethernet cable, and second hole is for other data connection cables
- 3- Connect the ethernet cable to RJ45 port which is located at the bottom of the terminal board.
- 4- Route the data cable underneath the terminal board.
- 5- Remove the data connection socket on the terminal board. Connect data cables to data connection socket by pushing the top of the each connection point on the data socket with a small flat screw driver. Follow the "data connection table" for the correct order.
- 6- Connect the data connection socket back on the terminal board.
- 7- Set the "Switch 1" and "Switch 2" positions on the terminal board with respect to "data connection table".

NOTE : Below data connection cables can be inserted through the cable holes;

- a. External enable input cable
- b. External MID or TIC meter cables
- c. External current transformer cables
- d. Ethernet cable
- e. Load shedding triggering signal cable
- f. Shunt trip module control signal cable for welded relay contact failure

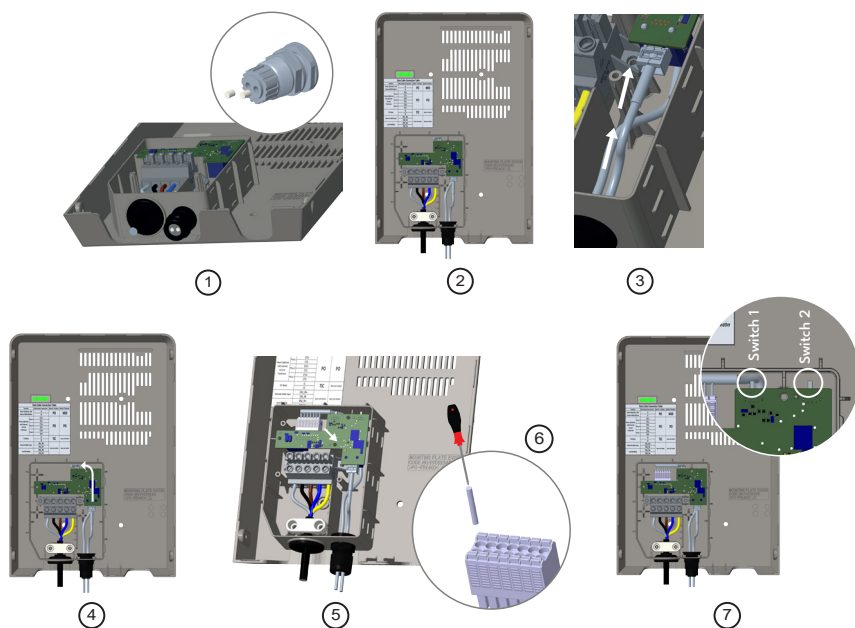

13.1 - EXTERNAL ENABLE INPUT FUNCTIONALITY

Your charging station has external potential free enable / disable functionality which can be used for integration of your charging station to an carpark automation systems, energy supplier ripple control devices, time switches, photovoltaic inverters, auxiliary load control switches, external key lock switches etc. Refer to "Data Cable Connection Table" for terminal board connection and setting details of externa enable input function. Externa enable input function can be enabled or disabled via web configuration interface. To activate the functionality please check web configuration interface.

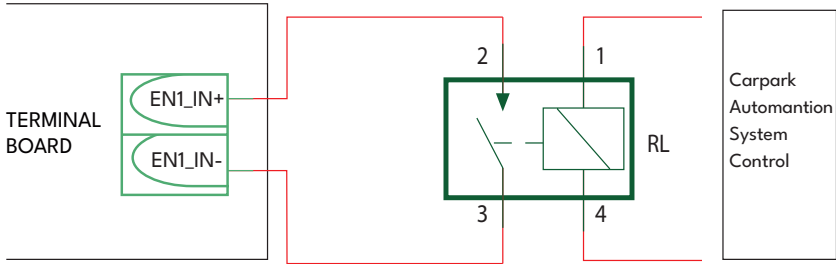

If the external relay (RL) is in non-conducting (open), the charging station will not be able to charge the electric vehicle.

You can connect potential free input signals as shown in above circuitry (see figure).

13.2 - POWER OPTIMIZER (REQUIRES OPTIONAL ACCESSORIES)

The EV charger has option to make single load balancing with different accessories.

1. Power Optimizer with External MID meter
2. Power Optimizer with External Current Transformer (CT)

To adjust the power optimizer, refer to "Data Cable Connection Table" for terminal board connection and setting details of power optimizer with current transformer or power optimizer with external MID. Power optimizer function can be enabled or disabled via web configuration interface. To activate the functionality please check web configuration interface.

This feature is provided with an optional metering accessories which are sold separately. In power optimizer mode, the total current drawn from the main switch of the house by charging station and other household appliances is measured with current sensor integrated to the main power line. Current limit of the main power line of the system is set via web configuration interface. According to the limit set by the user, charging station adjusts its output charging current dynamically according to the measurement of main power line.

13.2.1 - POWER OPTIMIZER WITH EXTERNAL MID METER

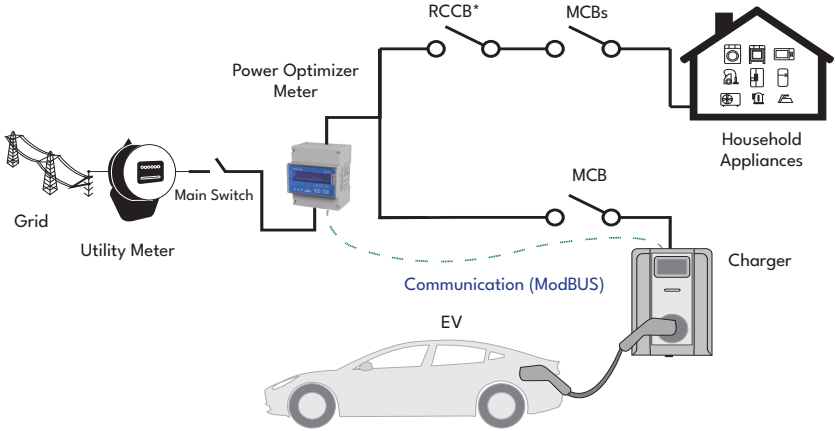

Power Optimizer Meter should be placed just after the main switch of the house as shown in the figure. Power Optimizer Meter wiring connections can be made according to the information below.

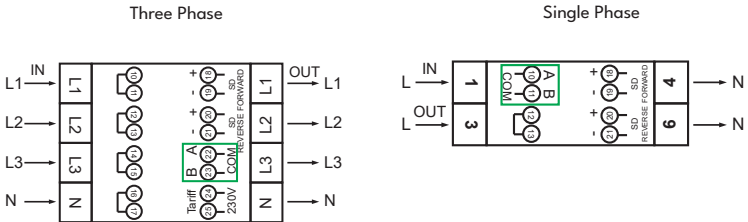

■ 22-23: A-B (COM) Modbus connection over RS485 for three phase charging station models.

■ 10-11: A-B (COM) Modbus connection over RS485 for single phase charging station models.

For the modbus cable connection and setting details on the terminal board, please refer to "Data Cable Connection Table"

13.2.2 - POWER OPTIMIZER WITH EXTERNAL CURRENT TRANSFORMER (CT) (Optional)

In external CT transformer usage; for Power Optimization (dynamic load management) to be used with household appliances and EV Charger together, 1 piece of External Current Transformer (FATS16L-100) is used for monophasic EV Charging installation and 3 pieces of External Current Transformers are used for three-phase installation. In power optimizer mode, the total energy drawn from the main switch of the house by charging station and other household appliances is measured with the help of this current transformer installed to the main power line. The charging station regulates the charging power of the electric vehicle according to the load on main switch of the house.

To adjust the power optimizer with current transformer, refer to "Data Cable Connection Table" for terminal board connection and setting details of power optimizer with current transformer. also refer to web configuration interface for setup of the power optimizer with current transformer.

The power optimizer with external CT should be placed as shown in the figure below.

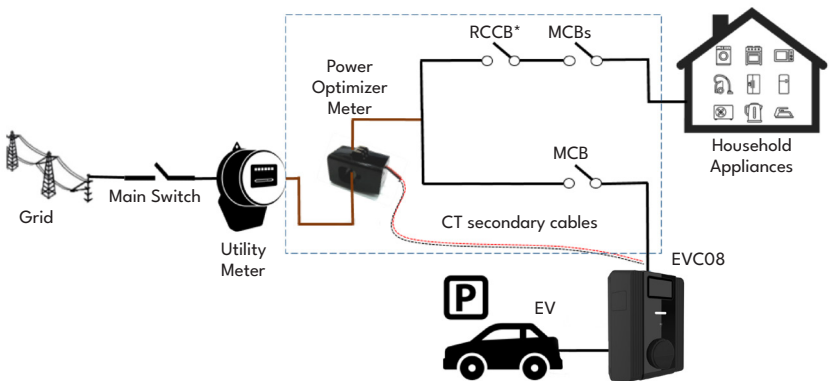

13.3 - LOAD SHEDDING

This charging station supports load shedding functionality which provides immediate charging current reduction in case of limited supply. Load shedding functionality can be used in any mode including Standalone and OCPP connected modes. Load shedding triggering signal is a dry contact signal which must be provided externally and connected to the terminal board which is listed in "Data Cable Connection Table". Load shedding can be enabled or disabled via web configuration interface. When load shedding is activated by closing the contacts with an external device (Eg. ripple control receivers etc.) charging current reduces down to 8A. Limited charging current value can be reset via web configuration interface. When load shedding is deactivated by opening the contacts charging continues with maximum available current. In normal use case when there is no signal connected to the load shedding input (contacts open between terminal 3 and 4) charging station supplies maximum available current.

14 - FACTORY RESET

When the service cover is disassembled by removing the secure screws with torx T20 security L-Allen or screwdriver adapter using torx T20 security bit, the factory reset will be activated by pressing and releasing the tamper switch 5 times in a 20-second total time period, provided that the process starts from the position where the tamper switch is released. To press and release the tamper switch, service cover can be used.



15 - COMMISSIONING & OCPP CONNECTION

OCPP connection can be achieved via WIFI, ethernet or cellular network. WIFI and ethernet are standard for th EVC08 where cellular is an option.

15.1 - CONNECT OCPP OVER CELLULAR NETWORK (OPTIONAL)

Disassemble the service cover by removing the secure screws with torx T20 security L-Allen or screwdriver adapter using torx T20 security bit to access the micro SIM card slot. Insert the SIM card with respect to below figure. Then replace the service cover and tighten the security screws.

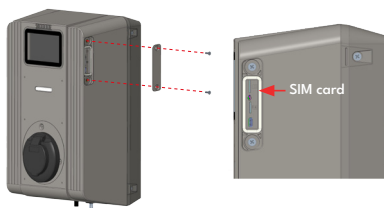

15.2 - COMMISSIONING

If you want to connect the charging station's web configuration interface, you have two options;

- a. You can directly connect your PC to the charging station using a patch Ethernet cable. If you follow this option, please make sure that you have properly configured your charging station's LAN interface to static IP.
- b. You can use a router having DHCP server. In this option, both the charging station and the PC should be connected to the router. Please be sure that you need to check the IP address from the router to be able to make the connection.

15.2.1 - CONNECT PC TO THE SAME NETWORK WITH SMART BOARD

In order to access web configuration interface, first you need to connect your PC and EV charger to the same ethernet switch or connect EV charger to your PC directly.

Default IP address of HMI board is 192.168.0.10. For this reason, you need to give static IP to your PC in the same network with HMI board.

You should assign static IP address to your PC in 192.168.0.0 network which means that IP address should be in a range of between 192.168.0.1 and 192.168.0.254.

15.2.2 - OPENING WEB CONFIGURATION INTERFACE VIA WI-FI HOTSPOT

For this unit, when accessing to Wi-Fi Hotspot settings in the WEB User Interface, under Network Settings tab, Wi-Fi Hotspot can be enabled or disabled. Also, optionally timeout activated can be changed as 5-30 minutes or continuous.

During the Wi-Fi Hotspot timeout duration, it is possible to connect a smart device (mobile phone, tablet or laptop) to the charging station.

Each product has a Wi-Fi Hotspot SSID and Wi-Fi Hotspot password set as factory configuration. Wi-Fi Hotspot SSID and Wi-Fi Hotspot password informations are located on the label pasted to the Quick Start Guide. You can log in to the Web configuration interface via Wi-Fi Hotspot by entering the network information written on the label.

After connecting to the "Wi-Fi Hotspot" network, the user can open the WEB browser from the computer or mobile device and type the IP address of the charging station, Wi-Fi Hotspot at IP-Address is written on the label.

For Android mobile devices, it is necessary to configure the browser to download and display the desktop site from the menu in the upper right corner of the Chrome browser. For iOS mobile devices, it is necessary to configure the browser to download and show the desktop site from the menu in the top right corner and also set the text size to 50% in the AA setting in the top left corner of the Safari browser.

Note: Maximum 3 users can connect to WEB Configuration Interface via Wi-Fi hotspot. It supports 2.4Ghz.

15.2.3 - OPENING WEB CONFIGURATION INTERFACE WITH BROWSER

Open your web browser and type 192.168.0.10 which is IP address of HMI board.

You will see login page on your browser;

Each product has a user name and password set as factory configuration.

In this section you can log in to the Web configuration interface by entering the configuration information printed on the label. User Name and Password informations are located on the label pasted to the Quick Start Guide or first page of Installation Guideline as shown below.

Only for the first login you will be forced to change your password.

You can change password with Change Password Button in WEB UI login page or Administration Password section in the System Maintenance tab.

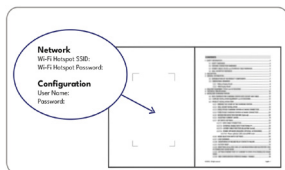

Visual representation is provided

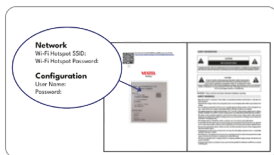

Visual representation is provided

Attention: For web configuration interface accessibility problems; Web browsers usually save some information from websites in its cache and cookies. Forcing Refresh or Clearing (depending on your operating system and browser) them fixes certain problems, like loading or formatting issues on web page.

In case of security warning via web browser due to expired SSL certificate, please proceed to webpage connection.

After logging in for the first time using the default credentials, you will be prompted to review and confirm the Privacy Policy.

You must check the box "I read, I understand" and click "Confirm" to continue to the interface.

16 - WEB CONFIGURATION INTERFACE

MAIN PAGE

The Main page provides an overview of the key system information and connection status of the EVC device. Below are the descriptions of each displayed parameter:

User Name: Username of the logged-in user.

CP Serial Number: Unique serial number of the device. It is used for device authentication and remote management.

HMI Software Version: The software version of smart board (HMI) that runs the device's touchscreen interface.

OCPP Software Version: The version of the Open Charge Point Protocol (OCPP) software, which enables communication with the charging network management system.

Power Board Software Version: The version of the software that controls power management and charging operations of device.

Duration after Power On: The total time (in hours, minutes, and seconds) that has passed since the device was last powered on. Useful for uptime tracking and performance monitoring.

Connection Interface: The current communication method used by device. It can be Ethernet, WLAN (Wi-Fi), or Cellular.

Ethernet Interface IP: The IP address assigned to device when connected via a wired Ethernet connection.

WLAN Interface IP: The IP address assigned when device is connected via Wi-Fi. (If not connected, this field will be empty.)

Cellular Interface IP: The IP address assigned when device is connected via a mobile network. (If not connected, this field will be empty.)

OCPP Device ID: Unique identification number used by device when communicating with OCPP server.

OCPP Hash: OCPP Hash is the cryptographic hash value of the OCPP software component running on the device. This value represents the current binary content of the OCPP software and is used to verify software integrity.

The hash value changes whenever any modification is made to the OCPP software (such as a software update, recompilation, or any other change).

Since the OCPP software implementation differs between single-socket and dual-socket devices, the OCPP Hash values may also differ between these device types.

This is expected behavior and results from differences in the software implementation.

	<p>Connector State: Indicates current status of device's charging connector.</p> <p>This information helps users better understand the details displayed on the main page of the web configuration interface.</p> <p>You can also change the web configuration interface language and log out of the web configuration interface with the buttons in the upper right corner of the page. The following languages are available:</p> <p>Turkish, English, German, French, Romanian, Spanish, Italian, Finnish, Norwegian, Swedish, Hebrew, Danish, Czech, Polish, Hungarian, Slovak, Dutch, Greek, Bulgarian, Montenegrin, Bosnian, Serbian, Croatian.</p>
--	--

16.1 - GENERAL SETTINGS

Display Language	Available languages will be listed, if display is available. The EV charger display language can be adjusted as desired.
Display Backlight Settings	To optimize visibility of display according to daylight conditions, Sunrise Time and Sunset Time can be selected when Backlight Level is time based.
Display Service Contact Info	<p>Customer care number to be shown on "Out of Order" screen. When the device gets an error, the Display Service Contact Info entered in this field will be displayed on the screen to assist with resolving the problem.</p> <p>If you want to show display service contact information on another screens like "Connect Charging Cable", "Preparing for Charging", "Initializing", "Waiting for Connection" screens you can enable the config from Show Extra Service Contact Info setting.</p> <p>(If charging station has a display.)</p>
Display QR Code	QR code can shown on screen or disabled. QR Code Delimiter, between CPID and ConnectorID of the text inside QR code.
LED Dimming Settings	To optimize visibility of status indicator LED according to daylight conditions, Sunrise Time and Sunset Time can be selected when Led Dimming Level is time based.
Standby LED Behaviour	Standby status indicator LED behaviour can be set as On or Off.
Display Theme	EV charger's display theme color can be set from this tab.
Logo Settings	Logo on the top-right corner of the display. You can change the Display logo with the upload button, You can only upload in png format and the size of the logo you choose must be 80x80. You can also remove the logo with the remove button.

Scheduled Charging

If the device is in Standalone Mode, you can only set Randomised Delay Maximum Duration and Continue Charging After Power Loss settings.

Randomised Delay Maximum Duration is the setting that allows device to apply a random delay time before charging starts and can take values between 0 and 1800. The device waits for a random time before starting the charging process. For example, if Randomized Delay Maximum Duration = 60 seconds, the device will apply a random delay between 0 and 60 seconds.

Off- peak Charging: If the device is in OCPP Mode, for this mode you should enabled OCPP Connection in OCPP Settings.

In OCPP Mode you can make all Off-Peak Charging settings. Off-Peak Charging is a feature that allows an electric vehicle to be charged during off-peak hours, when the grid is less busy.

Off- peak Charging at the Weekends: Time period of charging at weekends when the electricity demand is low (off-peak hours).

Off- peak Charging Second Time Period: Refers to charging in the second of the low electricity demand time periods. Some electricity tariffs offer more than one low-price time slot during the day.

For example:

First Off-peak time: 00:00 - 06:00 at night

2nd Off-peak time: 13:00 - 16:00 in the afternoon

This expression means that charging is done during the second off-peak hour. So you are charging during the second off-peak time slot instead of the first off-peak time slot.

Off- peak Charging Periods: User can determine set off-peak hours.

Randomised Delay At Off Peak End: When the low tariff hours end, charging is delayed for a random period of time.

Off-Peak End → End of low tariff (off-peak) hours

Randomized Delay → Random delay

Timezone: Refers to the local time zone in a particular region.

Continue Charging End Peak Interval: Continue charging at the end of the peak interval.

Continue Charging Without Reauth After Power Loss: Charging process will continue without requiring reauthorization after a power loss.

16.2 - INSTALLATION SETTINGS

Earthing system	In web configuration interface, earthing type is “TN/TT” by default. If Earthing Type is selected as IT, the protective earth error check is disabled.
Current Limiter Settings	Current Limiter Phase information can be adjusted in this menu. Also Current Limiter Value can be written manually between 6-32A. If a value below 6A is written, a warning will be shown to write minimum 6A. Note: The current limiter of the charging station can be set in hardware via the rotary switch or manually in the web configuration interface. There is no hardware or software configuration interface priority. The charging station uses the current value last set by the installer from either interface.
Unbalanced Load Detection	You can enable or disable the Unbalanced Load Detection. If enable option is selected, Unbalanced Load Detection Max Current can be selected. Unbalanced Load Detection Minimum value is 6, max value is Current Limiter Value. Current Limiter Value can be set on Current Limiter Settings.
External Enabled Input	You can enable or disable the External Enable Input.
Lockable Cable	You can enable or disable the Lockable Cable.
Charging Mode Selection and Power Optimizer Configuration	In this part, you can select Follow The Sun, Follow The Sun Mode, Auto Phase Switching, Operation Mode, Power Optimizer Total Current Limit and Power Optimizer External Meter. For a detailed explanation of Follow The Sun, please refer to section 16.2.1. Operation Mode can be Normal, Peak / Off-Peak, TIC without Peak / Off Peak. TIC Power Optimizer Total Current Limit can be Disabled or can take values between 10 and 100. When TIC selected in Operation Mode , Power Optimizer Total Current Limit and Power Optimizer External Meter can not be selected. When Power Optimizer Total Current Limit is Disabled, Power Optimizer External Meter can not be selected. Power Optimizer External Meter. can be selected Auto Selected, Klefr 6924 / 6934, Garo GNM3T / GNM3D, Embedded Power Optimizer with CT, P1 Slimmeter. If Power Optimizer External Meter is Auto Selected, Power Optimizer value reads from main board.
Load Shedding Minimum Current	Load Shedding Status is reading from main board, you can select Load Shedding Minimum Current from Web configuration. This parameter can take values between 0 and Current Limiter Value. Current Limiter Value can be set on Current Limiter Settings.

G100 Settings	<p>G100 settings allows you to enable or disable G100 Mode and select the Installation Type as either Domestic or Commercial.</p> <p>When the Installation Type is set to Domestic, the G100 OP State automatically changes to State - 3 which means the device has entered safety mode because the grid voltage or frequency has exceeded its limits. In this case, you can restart the device by pressing the G100 STATE-3 RESET button. However, this action can only be performed a limited number of times.</p> <p>If the G100 State-3 reset limit is reached to maximum, the admin can press the G100 LOCKOUT RESET button and confirm the action to exit the Excursion condition.</p> <p>In this part, to change the Installation Type to Domestic, ensure the following:</p> <ol style="list-style-type: none">1. If using Local Load Management, the Maximum Grid Current must be 100 or less.2. If using Power Optimizer, the Total Current Limit of the Power Optimizer must be 100 or less.
----------------------	---

16.2.1 - FOLLOW THE SUN

16.2.1.1 - Inverter Type and Mode Configurations with Different Measurement Methods

16.2.1.1.1 - Export Mode with the usage of CTs

Export Mode with the usage of CTs at the inverter output and input of the electrical consumer devices of the house. Inverter may only be single phase for CT usage and also supports energy export to grid.

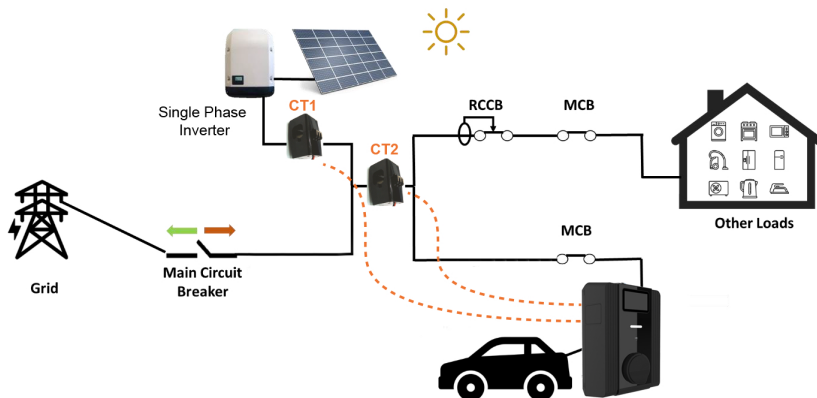

Figure 1

Place the CT1 and CT2 to mains lines with respect to Figure-1. Connect the CT1 and CT2 to terminal board with respect to data cable connection table. Set the switch 1 and switch 2 on terminal board to activate "power optimizer with external current transformer" with respect to data cable connection table.

NOTE: CAT5 cable length to use should be below 100 meters.

16.2.1.1.2 - Export Mode with the Usage of Utility Meter

Export Mode with the usage of Energy Meter at the Grid output.

Energy meter may be single phase or three phase for supports energy export to grid.

The energy meter KLEFR 6934 is used for a 3-phase installation or the model KLEFR 6924 for a 1-phase installation.

The total energy drawn from the main switch of the house by charging station and other household appliances is measured with this device integrated to the main power line. The charging station regulates the charging power of the electric vehicle according to the load on main switch of the house.

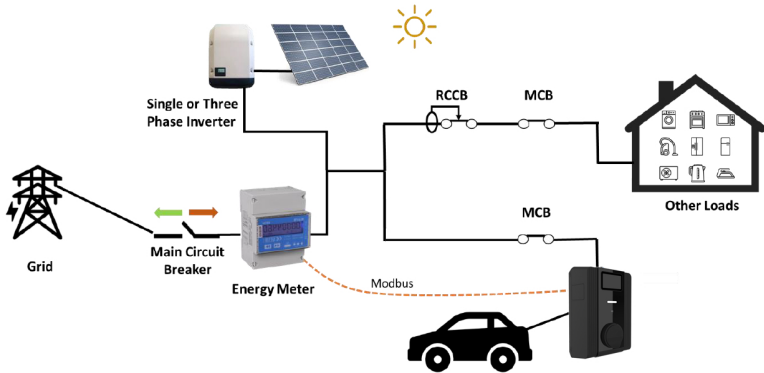

Figure 2

Energy Meter is connected to the terminal board with respect to data cable connection table.

The figures are just generic examples of power optimizer meter installation to a distribution box of the house, not to be exactly the same for the actual house installation.

Energy Meter wiring connections can be made according to the information below.

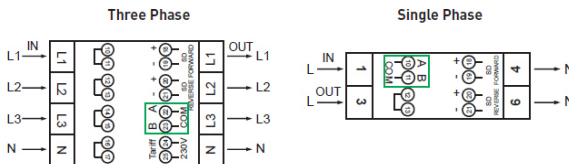

Figure 3

22-23: A-B (COM) Modbus connection over RS485 for three phase charging station models. (See the following section "Data Cable Connection Table")

10-11: A-B (COM) Modbus connection over RS485 for single phase charging station models. (See the following section "Data Cable Connection Table")

16.2.1.2 - Modes of Operation

Follow The Sun mode functionality can be enabled and disabled. If Follow The Sun mode is enabled; there are 3 options for the Follow The Sun;

16.2.1.2.1 - Sun Only

This mode is used for pure solar charging of the electric vehicle for least carbon footprint. When the user activates this mode, charging is only with energy from solar power generation. Vehicle can be charged with whatever solar generation is currently available, without using grid support at all. Charging is possible only with solar surplus. If solar generation is low, charging will not be possible.

16.2.1.2.2 - Sun Hybrid

This mode is used for solar charging with limited support from the grid when there is no solar generation. If solar generation is high enough, grid support won't be used. If solar generation is low, charging station will use grid support to be able to start charging. Eg. Solar generation is 3A and minimum charging current of the charging station is 6A, 5A will be used from the grid (minimum charging current is calculated as 8A because 6A + 2 A hysteresis). (CP min charging current is 6A for IEC 61851, 8A for ZE Ready 1 phase charging, 13A for ZE Ready 3 phase charging.)

Sun Only and Sun Hybrid modes can be overridden (forced charge) from Drive Green App and charging station will switch to max available charging current mode for that single charging session and will fallback to Sun Only mode after active charging session is finished.

16.2.1.2.3 - Max Hybrid

When the user activates this mode, the charging process should be a normal charging process that can charge at maximum power regardless of solar generation or grid support option.

16.2.1.3 - Auto Phase Switching

When the user activates the Follow the Sun, the charging station can automatically switch 1 phase/3 phase according to the amount of solar production and consumption.

16.3 - OCPP SETTINGS

OCPP Connection

If you select mode as “Enabled”; you should type all fields in the connection settings and configuration parameters sections are enable.

For now, the only available OCPP version is OCPP 1.6, so it will be selected as default.

The Central System Address and Charge Point Id are mandatory fields for saving this page.

You can set OCPP configuration parameters to their default values by clicking “Set to Defaults” button.

OCPP Ciphers Support: A cipher suite is a set of algorithms that help secure a network connection.

If “Ocpp Security Profile” is selected as 2 or 3, OCPP specification enforces one of two cipher suites to be used. If your backend uses a different cipher suite you can change this setting as “All Ciphers” but it will be incompatible to OCPP standard.

You can select the OCPP settings type you want from the menu which is at the left side of the page.

For example OCPP Connection, OCPP Version, OCPP Ciphers Support, Connection Settings and OCPP Configuration Parameters.

Then, click “Save” button.

Note: Be careful for your entered values because the system does not accept the unsuitable values and gives warning. In this case, values will not be saved. Then you will not be redirected to the main page so you should check your values.

PLUG & CHARGE (Optional):

ISO15118-2 PLUG&CHARGE function can be enabled/disabled under the “OCPP Settings” page by “ISO15118PnCEnabled” item. To be able to charge with PLUG&CHARGE function, EV shall also support the PLUG&CHARGE function.

16.4 - NETWORK INTERFACES SETTINGS

There are four types of network interfaces in this page; Cellular, Ethernet, Wi-Fi and Wi-Fi Hotspot. Select interfaces' modes as "Enabled" if you want to activate it. You should fill all spaces in suitable formats.

CELLULAR	<p>If "Static" is selected; "IMEI", "IMSI" and "ICCID" fields are mandatory. When cellular gateway is enabled, the LAN interface IP setting mode will be set to static and DHCP Server will be enabled.</p>
LAN	<p>If you select Ethernet or Wi-Fi IP Settings as "Static"; "IP Address", "Network Mask", Default Gateway" and "Primary DNS" spaces are mandatory.</p>
WLAN	<p>If you set Wi-Fi as enabled, "SSID", "Password" and "Security" are mandatory. A list of available wireless networks is displayed in the WLAN section.</p>
WIFI HOTSPOT	<p>Details are described in section "OPENING WEB CONFIGURATION INTERFACE VIA WIFI HOTSPOT".</p>
FIREWALL	<p>Input and output policies determine how the network is operated. Default policies in this area should be adjusted as needed by authorized people. Access to the device may be completely blocked after incorrect settings. This is not a software issue but a configuration error.</p> <p>These policies should be adjusted according to the whitelist or blacklist logic and the necessary rule configuration should be made for the desired situations.</p> <p>Status</p> <p>This setting controls the firewall status: "Enable" activates it, while "Disable" deactivates it. The "Disable" option turns off the firewall, preserving the status of all settings.</p> <p>Incoming Traffic</p> <p>This policy determines the default behavior for incoming traffic. The "Allow" option accepts all incoming traffic, while the "Deny" option rejects all incoming traffic.</p> <p>Outgoing Traffic</p> <p>This policy determines the default behavior for outgoing traffic. The "Allow" option accepts all outgoing traffic, while the "Deny" option rejects all outgoing traffic.</p> <p>Adding Custom Rules:</p> <p>Users can add custom firewall rules and select and delete them. To delete a rule, check the box in the "Select" column and click the "Delete" button. Rules are prioritized from top to bottom.</p> <p>The "Add" button will open a pop-up and the rules will be added to the list by making the necessary settings and pressing "Add".</p>

	<p>Policy: This setting determines whether to accept or reject a certain type of traffic. The “Allow” option allows the traffic, while the “Deny” option blocks the traffic.</p> <p>Direction: This setting determines which direction of traffic the rule applies to. The “Input” option targets incoming traffic, while the “Output” option targets outgoing traffic.</p> <p>Interface: This setting determines which network interface the rule is applied to. Options include “LAN”, “wlan”, “Cellular”, and “lo”.</p> <p>Protocol: This setting determines which communication protocol the rule is applied to. Options include “tcp”, “udp”, and “None”.</p> <p>Port: This setting determines which port number the rule is applied to. Users can add as many rules as they want and can edit or delete them as needed. This enhances the flexibility and convenience of your firewall application.</p>
<p>WEBCONFIG ACCESS PROTOCOL</p>	<p>HTTP does not provide encrypted communication. Sensitive data such as passwords may be exposed to attackers. HTTPS is recommended for secure communication.</p>

16.5 - STANDALONE MODE SETTINGS

If you have set OCPP as enabled in OCPP settings before, standalone mode cannot be selected. Otherwise, you can select standalone mode. There are three modes in the list;

Select “RFID Local List” mode to authenticate a RFID local list which will be entered by you. You can make an addition or deletion from the RFID local list later.

Select “Accept All RFID’s” mode to authenticate all RFID’s.

Select “Autostart” mode to allow charging without the need for authorization. It will be enough to plug to start charging.

If you are done with mode selection, click “Save” button and reboot the device.

For an in-depth overview of the LOCAL LOAD MANAGEMENT configuration settings, please refer to Section 16.7.

16.6 - MAKING SYSTEM MAINTENANCE OF THE DEVICE

Log Files	<p>In the Log Files page, you can download device event logs for a selected date range (maximum 5 days) using the Start Date and End Date fields. Device logs are automatically deleted every 30 days.</p> <p>You can also click CLEAR to permanently delete all event logs stored on the device.</p> <p>Download Change Logs: Within the scope of Personal Data Protection, all changes made to the device settings are kept. Saved logs of which users and which actions were taken can be downloaded with the “Download Change Logs” button.</p>
Firmware Updates	<p>You can upload the firmware update file from your PC, after the file is uploaded, click on “Update” button to start the firmware update.</p> <p>When update is started, your charger’s LED indication will be seen as constant red. With Display Models, the firmware update process is shown on the screen as follows:</p> <ol style="list-style-type: none"> 1-The firmware is sent, and the device begins uploading it. 2- While updating, the following warning will appear on the screen: "Updating Firmware! Please do not start charging while updating." 3- After 5 seconds, the display will automatically return to the home screen and the indicator "Connect charging cable" will appear on the screen. <p>After the firmware update is finished, your charger will restart automatically. You can see the latest firmware version of your charger from webconfig UI in main page.</p>
Configuration and Backup	<p>You can backup of the sytem. If you want to restore you can click the Restore Config File button and upload the backup file. The system only accepts the .bak files.</p>
System Reset	<p>You can proceed to this section to make Hard Reset and Soft Reset.</p>
Administration Password	<p>A password is required for administrative access.</p>
Factory Default Configuration	<p>You can reset your device to its factory settings.</p>
Local Charge Sessions	<p>From this page, you can download and view the full session log and charging summary, including the duration of charging and the RFID card used, in Excel format.</p>

16.7 - LOCAL LOAD MANAGEMENT OF THE DEVICE

The Local Load Management tab includes two parts: **General Settings** and **Load Management Group**.

GENERAL SETTINGS

If the device with dynamic local load management; local management option can be disabled, Modbus TCP or Master/Slave.

16.7.1 - Modbus TCP/IP Protocol Parameters

EVC08 charging station acts as a slave device in the Modbus TCP/IP communication. Charging station should be in the same network (via ethernet or WIFI) with the master device or a proper routing should be applied to provide communication between slave and the master devices in different sub networks. Each charging station should have different IP address. Modbus TCP communication port number is 502 and Modbus Unit ID is 255 for EVC08 charging stations. There can be only one active Modbus master connection at any time. When a new Modbus connection is established, the master is expected to set the Failsafe Current, Failsafe Timeout and Charging Current registers immediately. The master also periodically sets the Alive register to indicate that the connection is still alive. If the master does not update the value of the alive register until the failsafe timeout, the device switches to the failsafe state; TCP socket is terminated and failsafe current becomes active. As the update period of the Alive register, half of the failsafe timeout is recommended.

16.7.2 - Static Management

For static management, a power limit can be set to the load management group and the charger won't go above the power limit.

For the Load Management function to operate in Static mode, the Supply Type parameter in the menu of the device defined as Master must be set to "Static."

In a Static Load Management configuration, a predefined total current limit is assigned to a Load Management Group. This limit defines the maximum total current that all Electric Vehicle Chargers (EVCs) within the same group are allowed to draw simultaneously.

The Master device is responsible for distributing the charging current to each EVC within the cluster. While doing so, it ensures that the sum of the currents drawn by all devices does not exceed the configured group limit.

Unlike Dynamic Load Management (DLM) systems, the available current in static mode does not change dynamically based on grid load or building consumption. Instead, the system operates with a fixed and predefined current threshold, independent of real-time grid fluctuations.

This approach simplifies system configuration and provides predictable and stable load behavior. Therefore, Static Load Management is particularly suitable for installations with a fixed supply capacity or for infrastructures without real-time load feedback, such as systems where no energy meter is available.

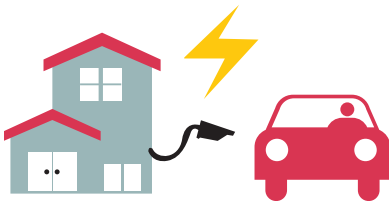

16.7.3 - Dynamic Management

With the help of dedicated power optimizer option, EV Charging station can manage the power limit based on the available power. When the household appliances consumes more, the charger consumes less and doesn't overload the main switch.

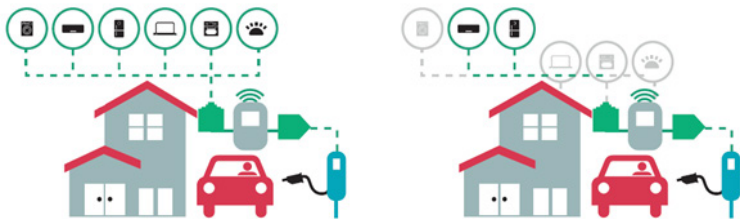

There are 2 different types of network topologies available for connecting multiple EVC08 charging stations in master/slave clusters. According to the customer needs, one of these alternatives can be chosen.

16.7.4 - Star Topology

In star network topology, all chargers are connected to the master station via a network switch or router. This topology needs cabling between each charging station and the central switch. This topology is more reliable than daisy chain topology since each charging station has its own connectivity to the network switch. For connection of each station to the central switch, Cat5e or Cat6 Ethernet cables can be used up to 100 meters each.

For the IP configuration of the network, either the router may have DHCP server or the master charging station can be configure as DHCP server. If you use a router with a DHCP server, you need to configure all charging stations including the master station LAN IP address setting as “Dynamic” from “Network Interfaces” menu. In this scenario, all the charging stations get their IP addresses from central DHCP server.

If you use a router or a L2-switch without DHCP server, you need to configure master charging station LAN IP settings to DHCP server and slave charging station LAN IP setting to “Dynamic” from “Network Interfaces” menu. In this scenario, slave charging stations get their IP addresses from master charging station.

Block diagrams for static and dynamic supply in star network topology are provided as below.

16.7.4.1 - Static Supply Star Topology:

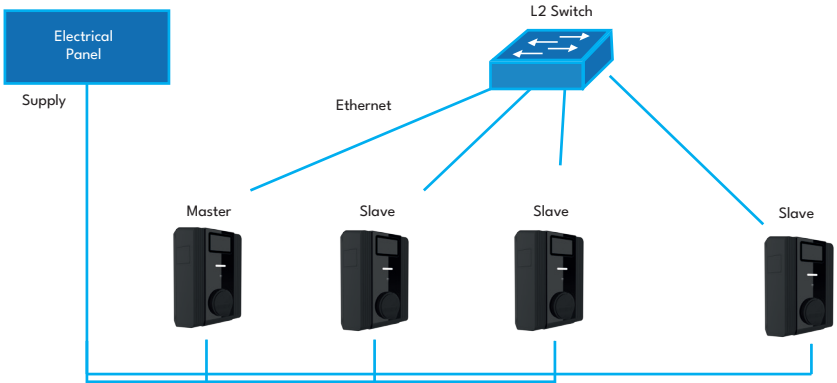

Local Load Management configuration of static supply.

16.7.4.2 - Dynamic Supply Star Topology:

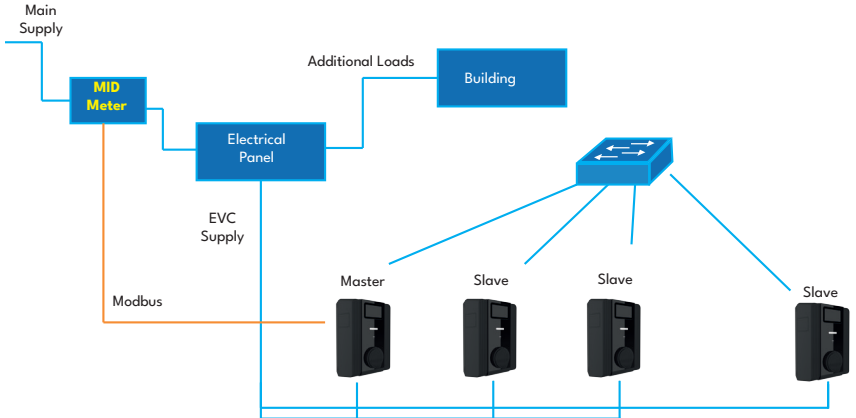

16.7.5 - Configuration of Charge Point Roles

If Load Management Option is selected as Master/Slave, there will be two part in this page; General Settings and Load Management Group.

Operation Selection on Web-UI

Users can select one of the following options:

- a. Master
- b. Slave
- c. Backup Master

16.7.5.1 - Configuration of Slave Charging Stations

The charging station is preconfigure to DHCP mode in factory. If you need to connect to the charging station's web configuration interface directly using a computer, rather than using a router having DHCP server, steps below should be followed:

- Make sure the charging station is powered-off and open the front cover of your charger which is mentioned in installation guideline.
- Charging station sets the Ethernet port to 192.168.0.10 address statically and subnet mask will be set to 255.255.255.0

To log in to the WEB Configuration User Interface, please refer to Section 15.2.3.

The master charging station should be set as DHCP server with a valid static IP address E.g. 192.168.0.10 with DHCP start and end IP addresses 192.168.0.50 and 192.168.0.100, respectively.

Note that if there is an external DHCP server in the local network, you also need to set master charging station to DHCP client.

Load Management option is **“disabled”** by default. After accessing to configuration web interface, you need to tab **“Local Load Management”** menu and select **“Master/Slave”** in **“Load Management Option”**. **“Charge Point Role”** should be selected as **“Master”**.

You can also select the DLM communication type from the **DLM Network Selection** dropdown. The available options are Ethernet and WLAN, depending on how the slave will communicate with the master.

Master charging station has additional configuration settings for dynamic load Management group.

Multi Master feature allows multiple DLMs to operate simultaneously on the same network, supporting up to 10 distinct clusters. Each cluster corresponds to a master node, and each master node manages its own dedicated grid to handle the current workload.

By default, the MultiMaster option is disabled. If the user wants to enable this option, they can do so via the web UI by enabling the MultiMaster feature and selecting the desired cluster value.

Note: It is important to remember that two multimaster configurations with the same cluster values cannot coexist on a single network.

The multimaster and cluster settings can be configured via the Master Configuration Settings page and the Slave Configuration Settings page in the web UI.

Grid Settings:

“**Maximum Grid Current**” value should be set to the maximum allowed current which can be drawn from the upstream electrical circuit.

“**Grid Protection Margin Percentage**” A safety margin is set for grid (electrical network) protection. It is usually used to prevent overloads or imbalances. The device limits itself to a certain percentage (%) to avoid damaging the network.

You must increase the **Maximum Grid Current** or decrease the **Grid Protection Margin Percentage** before saving the settings. The Maximum Grid Current limit cannot be lower than 10A when using the Grid Protection Margin Percentage.

The Cluster Max Current defines the maximum current that can be distributed among the connected nodes within the DLM system except home load in dynamic supply.

Cluster FailSafe Current represents the total available current when the external meter is no longer connected or has lost connection.

“**Supply Type**” should be set according to the load Management type such as “**static**” current limit or “**dynamic**” current limit. For static current limit, “Static” option should be selected. For dynamic current measurement, “**MID**” should be selected in “**supply type**”. Note that dynamic current limit setting needs optional current measurement accessories.

In the Supply Type option;

Static, Klefer 6924/6934 (The energy meter KLEFR 6934 is used for a 3-phase installation or the model KLEFR 6924 for a 1-phase installation.), **TIC** (TIC is a communication interface used in the smart meter Linky systems provided by distribution companies in France.), **GARO GNM3T/GNM3D** (Digital energy meters for 3-phase system, supports the Modbus protocol.) and **P1** (Power optimizer) can be selected.

Load Management Mode, can be selected from three options as “**Equally shared**”, “**First in First out**” and “**Combined**” modes. Combined mode needs extra configuration as “**FIFO Charging Percentage**” which effects the share between equally shared and first-in first-out calculations of the load management algorithm.

There are 3 different scenarios of load Management usage:

16.7.5.2 - Equally shared

All available power is distributed equally to all EVs connected. This is more suitable for workplace or condominium chargings where the cars are parked for a considerable period of time.

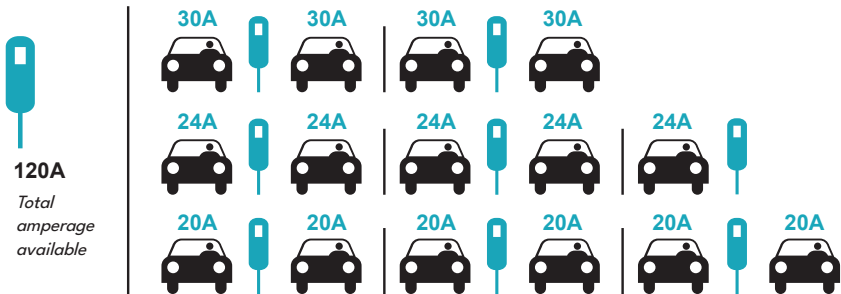

16.7.5.3 - FiFo (First in - First Out)

This type of load management is more oriented for fleets in order to let them have more fully charged EVs when they need. The available power is redistributed and when a new EV arrives, it waits until an EV finishes its charge or leaves the charging point.

EVSE/Tp	Gm = 120A						Gm = 80A	
	T1	T2	T3			T4	T5	T6
1	32A	32A	32A	32A	16A ↓	6A	6A	
2	32A	32A	32A	32A	32A	32A	32A	
3	32A	32A	32A	32A	32A	32A	32A	
4	32A	24A	24A	18A	32A	32A	6A	
5	32A	24A	6A	6A	8A	24A	6A	

* Tp: Time Period, Gm = Maximum Grid allocated for the chargers. Available maximum current for each EVSE in a certain Tp is indicated in black color. Charging current which is drawn by EV is indicated in Blue color. An EV drawing less current is incated by "↓" symbol.

16.7.5.4 - Combined Load Management

Combined load management is a combination of FiFo and Equally shared methods. A percentage of total power allocated for EV charging cluster can be set and this percentage of total power distributed to all EVs according to FiFo and the remaining power will be delivered as equally shared principal to all EVs.

EVSE/Tp	F% =50		Gm = 120A				Gm = 80A		Gm=29A	Gm = 30A
	T1	T2	T3	T4	T5	T6	T7	T8	T9	T10
1	32A	32A	32A	32A	20A ↓	6A ↓	6A	8A		6A
2	32A	32A	32A	32A	32A	32A	32A	32A	32A	6A
3	32A	32A	32A	32A	32A	32A	26A	28A	32A	6A
4	32A	24A	24A	12A	24A	32A	8A	10A	32A	6A
5	32A	24A	24A	12A	12A	18A	8A	10A	32A	6A

* Tp: Time Period, Gm = Maximum Grid allocated for the chargers. Available maximum current for each EVSE in a certain Tp is indicated in black color. Charging current which is drawn by EV is indicated in Blue color. An EV drawing less current is incated by "↓" symbol.

16.7.5.5 - Configuration of Backup Master

The "Backup Master" role provides redundancy in a Dynamic Load Management (DLM) network. In the event of the primary "Master" CP becoming unavailable, the "Backup Master" will automatically take over the master functions, ensuring continued operation and load balancing for connected slave CPs.

To configure a CP as a "Backup Master":

Ensure "Load Management Option" is set to "Master/Slave". (This is the default and necessary for both Master and Backup Master roles). From the "Charge Point Role" dropdown menu, select "Backup Master".

Read-Only Settings (Important):

Once "Backup Master" is selected, all other configuration settings on the "Local Load Management" page will become read-only. This is a critical design feature to ensure consistent and predictable behavior for the Backup Master, as its primary function is to replicate the Master's configuration and assume its role if needed.

DLM Master and Backup Master Switching

If the Main Master becomes unavailable, the Backup Master automatically takes control to ensure continuous system operation.

- Once the Main Master is active again, it checks the status of the Backup Master to confirm its readiness.
- If the Backup Master is still active, the Main Master resumes communication directly with it to synchronize the network.
- The Backup Master then returns to standby mode, allowing the Main Master to fully take over again.
- All connected nodes automatically reconnect to the Main Master without requiring user intervention.

DLM Master and Backup Master Data Synchronization

The "Master" and "Backup Master" are designed to continuously synchronize DLM settings and slave data to ensure a seamless failover experience. This synchronization occurs:

- **During Power-Up:** The "Backup Master" requests and receives the latest settings and slave data from the "Master".
- **During Runtime:** The "Master" pushes updated DLM settings and slave data to the "Backup Master" whenever changes occur.

Backup Master Operational Behavior:

When in Standby Mode (Main Master active): When the Main Master is operational and recognized by the Backup Master, the Backup Master remains in a standby state, continuously synchronizing data from the Main Master. The WebUI will display 'Backup Master' as the CP Role, and all other Local Load Management settings will be read-only.

When Operating as the Active Master (after failover): If the primary Master becomes unavailable (e.g., due to power loss or network disconnection), the configured Backup Master will automatically detect this and assume the active Master role after a set timeout. While functioning as the active Master, it will control the DLM network and allow disconnected Slave CPs to reconnect. The WebUI configuration for this CP will still show 'Backup Master' as the selected role, and all other settings will remain read-only.

LOCAL LOAD MANAGEMENT - LOAD MANAGEMENT GROUP

After the basic load management configurations are finished, be sure to connect all of the slave charging stations to the master charging station through daisy chain or star network topology.

When all the charging stations are ready to communicate with the master charging station, click “UPDATE DLM GROUP” button in “Load Management Group” menu. When “UPDATE DLM GROUP” button is clicked, master charging station starts slave discovery mode and automatically finds and lists slave charging stations in the list including master charging station itself as connector.

After master charging station discovers all the slave charging stations, then you can make other required settings of each connector one by one. After selecting the slave serial number the respective slave information will be visible.

If the selected connector is required to be prioritized over the other charging stations, you can set “VIP Charging” as enabled.

For setting the actual phase connection sequence of each charging station, you need to select correct sequence from the dropdown menu.

Note that if the charging station has only one phase supply, then you just need to select correct phase number from the drop down menu.

Until connection is alive operating with available current, when connection lost with network then operating with fallback current it is not compulsory until click in the block.

Other parameters of slave are just read only information from the connectors, which can be updated to the latest values by refreshing the configuration web interface.

Similar to slave list for each slave we have connector list and can select specific connector number from list of connectors and It will show updated information of respective connector as connector state, Instant Current and Available.

17 - UK REGULATION CHANGES ACCORDING TO SMART CHARGING (OPTIONAL)

CONFIGURATION WEB INTERFACE SETTINGS

Randomised Delay and Off-Peak Charging Behaviour

- a.** Randomised delay won't be repeated if applied in a charging period (except after power off and second transition to off peak hour, E.g: charging starts at 15:00 and paused at 16:00, when starting at 22:00 again randomized delay will be applied again.)
- b.** Randomised delay and waiting for off-peak charging will be cancelled if user tap RFID card for forced charging (first tap if charging station is in autostart mode, second tap if the charging station is in authorized mode). If the unit is in autostart mode any RFID card will force a charge, if the unit is in authorized mode the authorizing card of that charging session will force charge. Forced Charge will cancel both off-peak hour waiting period and randomized delay for that charging session.
- c.** While starting a charge session, if the time is in a peak period, the charging start will be delayed to the upcoming off-peak period start time. Randomized delay will be applied when the charging (actual energy transfer) starts.
- d.** If the time is in off-peak period, the randomized delay will be applied (if enabled) and then charging will start after delay. (It is only a numerical value and should be 600 by default). During the charging session if the time shifts from off-peak to peak, charging will continue or pause according to the setting "ContinueAfterOffPeakHour".
- e.** If unit has a screen "Waiting for off-peak hour, charging will start at hh:mm" will be shown on the screen while OCPP mode is active.
- f.** If unit has a screen, "Waiting for random delay, Charging will start at hh:mm" will be shown on the screen while OCPP mode and random delay mode are active sync of the time information from the server.
- g.** If a unit can connect to a central system, it will show exact charging start time on the screen. If a unit can not sync local time from the server due to either a connection issue or the unit is used locally without connection, it will only show the remaining time to start the charging session.
- h.** If unit does not have screen then waiting for off-peak hour will be shown on LED as Blue-Red blinking. (will be shut of after 5 mins)
- i.** If unit does not have a screen then randomised delay will be shown on LED as Green blinking.

OCPP mode change config items:

- i.** RandomisedDelayMaxSeconds: [0, 1800] (Default:600, can be set to "0" for disabling)
- ii.** CurrentSessionRandomDelay: random delay value calculated for active charging session. The value will be decremented by 1 minute intervals with time passes. (subject to change)
- iii.** OffPeakCharging: TRUE / FALSE (Default: TRUE)
- iv.** OffPeakChargingWeekend: TRUE / FALSE (Default: FALSE)
- v.** OffPeakChargingTimeSlots: 11:00-16:00, 22:00-08:00 (Default: 11:00-16:00, 22:00-08:00)
- vi.** ContinueAfterOffPeakHour: TRUE / FALSE (Default: FALSE)
- vii.** ContinueChargingAfterPowerLoss: TRUE / FALSE (Default: TRUE)
- viii.** ForcedCharging: TRUE / FALSE (Default: False, OCPP CS may set this to TRUE for overriding randomised delay and off-peak and after the charging session charging station will set this to FALSE again.)

Standalone / Local RFID List:

Webconfig General Settings menu “Smart Charging” tab:

Off-peak charging function will be active if and only if device is connected to the central system.

For the unit in standalone mode the settings will be as above. For Standalone modes, off peak charging will be hidden because of the time sync issue.

Randomised Delay Maximum Duration, can take values between 0 and 1800.

VESTEL

MOBILITY

