



ELECTRIC VEHICLE CHARGER EVC08 LIVEO SERIES

User Manual



CONTENTS

1 - SAFETY INFORMATION	3
1.1 - SAFETY WARNINGS.....	3
1.2 - GROUND CONNECTION WARNINGS	4
1.3 - POWER CABLES, PLUGS AND CHARGING CABLE WARNINGS	4
1.4 - WALL MOUNTING WARNINGS	4
2 - GENERAL INFORMATION.....	5
2.1 - INTRODUCTION OF THE PRODUCT COMPONENTS	5
2.2 - PLUG CHARGING CABLE	6
2.2.1 - SOCKET EQUIPPED MODEL	6
2.2.2 - ATTACHED CABLE MODEL.....	6
2.3 - BEHAVIOUR OF THE STATUS INFORMATION LED	7
3 - DESCRIPTION.....	9
4 - TECHNICAL SPECIFICATION.....	10
5 - CONNECTIVITY	10
6 - OTHER FEATURES (CONNECTED MODELS)	10
7 - AUTHORIZATION	11
8 - MECHANICAL SPECIFICATIONS	11
9 - ENVIRONMENTAL TECHNICAL SPECIFICATIONS	11
10 - CHARGING	12
10.1 - STANDALONE USAGE MODES	12
10.1.1 - AUTOSTART CHARGING MODE	12
10.1.1.1 - SOCKET EQUIPPED MODEL	13
10.1.1.1.1 - VEHICLE CONNECTION & CHARGING	13
10.1.1.1.2 - STOP CHARGING	14
10.1.1.2 - ATTACHED CABLE MODEL.....	15
10.1.1.2.1 - VEHICLE CONNECTION & CHARGING	15
10.1.1.2.2 - STOP CHARGING	16
10.1.2 - RFID AUTHORIZED MODE	17
10.1.2.1 - REGISTERING USER RFID CARD	17
10.1.2.1.1 - ADD/DELETE RFID CARD TO/FROM LOCAL RFID LIST:	17
10.1.2.2 - VEHICLE CONNECTION & CHARGING	17
10.1.2.2.1 - SOCKET EQUIPPED MODEL.....	17
10.1.2.2.1.1 - VEHICLE CONNECTION & CHARGING	17
10.1.2.2.1.2 - STOP CHARGING	19
10.1.2.2.2 - ATTACHED CABLE MODEL	20
10.1.2.2.2.1 - VEHICLE CONNECTION & CHARGING	20
10.1.2.2.2.2 - STOP CHARGING	22
10.1.3 - SMART APPLICATION AUTHORIZED MODE (OPTIONAL WITH WI-FI)	23
10.1.3.1 - CONFIGURING DRIVE GREEN APPLICATION.....	23

10.1.3.2 - DRIVE GREEN CONFIGURATION	23
10.1.3.3 - VEHICLE CONNECTION & CHARGING	24
10.1.3.3.1 - SOCKET EQUIPPED MODEL	24
10.1.3.3.1.1 - VEHICLE CONNECTION & CHARGING	24
10.1.3.3.1.2 - STOP CHARGING	26
10.1.3.3.2 - ATTACHED CABLE MODEL	27
10.1.3.3.2.1 - VEHICLE CONNECTION & CHARGING	27
10.1.3.3.2.2 - STOP CHARGING	29
10.1.3.4 - APPLICATION MODES	30
10.1.3.4.1 - ECO CHARGE MODE	30
10.1.3.4.2 - DELAY CHARGE FUNCTION	31
10.1.3.4.3 - LOCKABLE CABLE FUNCTION	31
10.1.3.4.4 - MASTER AND USER RFID CARD RESET	32
10.1.3.4.5 - POWER OPTIMIZER SETTINGS	32
10.1.4 - RFID LOCAL LIST AUTHORIZED MODE & ACCEPT ALL RFIDS MODE	33
10.1.4.1 - SOCKET EQUIPPED MODEL	33
10.1.4.1.1 - VEHICLE CONNECTION & CHARGING	33
10.1.4.1.2 - STOP CHARGING	35
10.1.4.2 - ATTACHED CABLE MODEL	36
10.1.4.2.1 - VEHICLE CONNECTION & CHARGING	36
10.1.4.2.2 - STOP CHARGING	38
10.2 - OCPP CENTRAL SYSTEM CONNECTED MODE (OPTIONAL)	39
10.2.1 - SOCKET EQUIPPED MODEL	39
10.2.1.1 - VEHICLE CONNECTION & CHARGING	39
10.2.1.2 - STOP CHARGING	41
10.2.2 - ATTACHED CABLE MODEL	42
10.2.2.1 - VEHICLE CONNECTION & CHARGING	42
10.2.2.2 - STOP CHARGING	44
10.2.3 - OCPP 1.6 JSON ADDITIONAL FEATURES	45
10.2.3.1 - RESERVATION FEATURE	45
10.2.3.2 - REMOTE CHARGE INITIATION / TERMINATION	45
10.2.3.3 - HARD RESET/ SOFT RESET	45
10.2.3.4 - UNLOCKING THE SOCKET	45
11 - MID METER MODELS (OPTIONAL)	50
12 - ERROR AND FAULT CONDITIONS	50
12.1 - GENERAL ERROR CONDITION	50
12.2 - OTHER ERROR CONDITIONS	51
12.3 - ON BOARD TYPE-A RESIDUAL CURRENT DEVICE	51
13 - CLEANING AND MAINTENANCE	52
14 - UK REGULATION CHANGES ACCORDING TO SMART CHARGING (OPTIONAL)	52

1 - SAFETY INFORMATION



CAUTION
RISK OF ELECTRIC SHOCK



CAUTION: ELECTRIC VEHICLE CHARGER DEVICE SHALL BE MOUNTED BY A LICENSED OR AN EXPERIENCED ELECTRICIAN AS PER ANY REGIONAL OR NATIONAL ELECTRIC REGULATIONS AND STANDARDS IN EFFECT.



CAUTION



AC grid connection and load planning of the electric vehicle charging device shall be reviewed and approved by authorities as specified by the regional or national electric regulations and standards in effect.

For multiple electric vehicle charger installations the load plan shall be established accordingly. The manufacturer shall not be held liable directly or indirectly for any reason whatsoever in the event of damages and risks that are borne of errors due to AC grid supply connection or load planning.

IMPORTANT - Please read these instructions fully before installing or operating

1.1 - SAFETY WARNINGS

- Keep this manual in a safe place. These safety and operating instructions must be kept in a safe place for future reference.
- Check that the voltage marked on the rating label and do not use charging station without appropriate mains voltage.
- Do not continue to operate the unit if you are in any doubt about it working normally, or if it is damaged in any way - switch off the mains supply circuit breakers (MCB and RCCB). Consult your local dealer.
- The ambient temperature range should be between $-25\text{ }^{\circ}\text{C}$ and $+50\text{ }^{\circ}\text{C}$ without direct sunlight and at a relative humidity of between 5 % and 95 %. Use the charging station only within these specified operating condition.
- The device location should be selected to avoid excessive heating of the charging station. High operating temperature caused by direct sunlight or heating sources, may cause reduction of charging current or temporary interruption of charging process.
- The charging station is intended for outdoor and indoor use. It can also be used in public places.
- To reduce the risk of fire, electric shock or product damage, do not expose this unit to severe rain, snow, electrical storm or other severe weathers. Moreover, the charging station shall not be exposed to spilled or splashed liquids.
- Do not touch end terminals, electric vehicle connector and other hazardous live parts of the charging station with sharp metallic objects.
- Avoid exposure to heat sources and place the unit away from flammable, explosive, harsh, or combustible materials, chemicals, or vapors.

- Risk of Explosion. This equipment has internal arcing or sparking parts which should not be exposed to flammable vapors. It should not be located in a recessed area or below floor level.
- This device is intended only for charging vehicles not requiring ventilation during charging.
- To prevent risk of explosion and electric shock, ensure that the specified Circuit Breaker and RCD are connected to building grid.
- The lowest part of the socket-outlet shall be located at a height between 0,5 m and 1,5 m above ground level.
- Adaptors or conversion adapters are not allowed to be used. Cable extension sets are not allowed to be used.



WARNING: Never let people (including children) with reduced physical, sensory or mental capabilities or lack of experience and or knowledge use electrical devices unsupervised.



CAUTION: This vehicle charger unit is intended only for charging electric vehicles not requiring ventilation during charging.

1.2 - GROUND CONNECTION WARNINGS

- Charging station must be connected to a centrally grounded system. The ground conductor entering the charging station must be connected to the equipment grounding lug inside the charger. This should be run with circuit conductors and connected to the equipment grounding bar or lead on the charging station. Connections to the charging station are the responsibility of the installer and purchaser.
- To reduce the risk of electrical shock, connect only to properly grounded outlets.
- **WARNING :** Make sure that during installing and using, the charging station is constantly and properly grounded.

1.3 - POWER CABLES, PLUGS and CHARGING CABLE WARNINGS

- Be sure that charging cable is Type 2 socket compatible on charging station side.
- A damaged charging cable can cause fire or give you an electric shock. Do not use this product if the flexible Charging cable or vehicle cable is frayed, has broken insulation, or shows any other signs of damage.
- Ensure that the charge cable is well positioned thus; it will not be stepped on, tripped over, or subjected to damage or stress.
- Do not forcefully pull the charge cable or damage it with sharp objects.
- Never touch the power cable/plug or vehicle cable with wet hands as this could cause a short circuit or electric shock.
- To avoid a risk of fire or electric shock, do not use this device with an extension cable. If the mains cable or vehicle cable is damaged it must be replaced by the manufacturer, its service agent, or similarly qualified persons in order to avoid a hazard.

1.4 - WALL MOUNTING WARNINGS

- Read the instructions before mounting your charging station on the wall.
- Do not install the charging station on a ceiling or inclined wall.
- Use the specified wall mounting screws and other accessories.
- This unit is rated for indoor or outdoor installation. If this unit is mounted outdoors, the hardware for connecting the conduits to the unit must be rated for outdoor installation and be installed properly to maintain the proper IP rating on the unit.

2 - GENERAL INFORMATION

2.1 - INTRODUCTION OF THE PRODUCT COMPONENTS

Socket Equipped Models

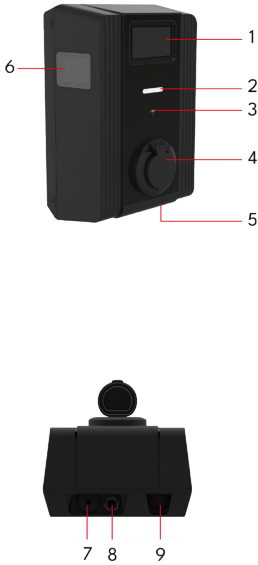

EN Socket Models

- 1- Information Display (optional)
- 2- Status indicator LED
- 3- RFID Card Reader
- 4- Socket Outlet
- 5- Product Label
- 6- MID Meter
- 7- Charging station connection cable union nut
- 8- Charging station Ethernet connection cable gland nut
- 9- Out of use

Tethered Cable Models



EN Tethered Cable Models

- 1- Information Display (optional)
- 2- Status indicator LED
- 3- RFID Card Reader
- 4- Product Label
- 5- AC Plug Holder (optional)
- 6- Charging Plug
- 7- MID Meter
- 8- Charging station connection cable union nut
- 9- Charging station Ethernet connection cable gland nut
- 10- Charging cable

2.2 - PLUG CHARGING CABLE

2.2.1 - SOCKET EQUIPPED MODEL

Open the front cover of the socket outlet and plug the charging cable to the socket outlet.







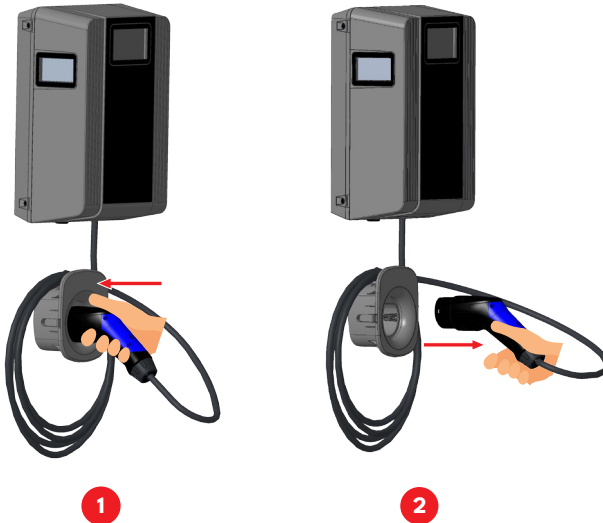



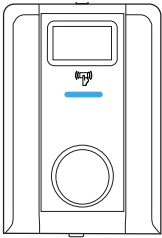







2.2.2 - ATTACHED CABLE MODEL













Press the button on top of the charging plug holder in order to release charging plug from the charger, and unplug the charging plug. Then plug the charging plug to the vehicle to start charging.



2.3 - BEHAVIOUR OF THE STATUS INFORMATION LED



Status of the LED		Status of the Charging Station
	Blinks Blue and Green	Charging station is starting up / booting.
	No LED Indication	Charging device is ready to charge. Finished charging with RFID card
	Blinks blue 4 sec	Electric Vehicle is connected. Charging Station is waiting for RFID card authorisation
	Green Glowing	Charging is authenticated.
	Blue Glowing	Charging in progress
	Constant Blue	Charging suspended or finished
	Constant Red	Fault condition
	Blinks red 4 sec	Ventilation required mode
	Blinks purple 4 sec	Charging with current limited to 16A due to over temperature
	Blinks purple 2,4 seconds OFF 1,2 seconds ON	TIC Communication Error
	Constant Purple	Charging not possible due to over temperature or power optimizer current limit is reached or the charger is disabled
	BlinksRed 10 seconds ON 2 seconds OFF	Over Voltage, Under Voltage, Protective Earth Or Phase Reversal Fault, Installation Error
	Blinks red and blue 1 sec	Charging station is reserved. Charging station is waiting for Eco Time interval and Waiting in Peak Hours Mode.
	Constant Red	Firmware update
	Blinks red Per second for 60 seconds 1 sec	Master Card Config mode / Local Card List Reset

Status of the LED		Status of the Charging Station
	Blinks blue in every 2 secs	Waiting to Tap User RFID card.
	Blinks green for 2 times	User RFID Card addition to local RFID list
	Blinks red for 2 times	User RFID card removes from local RFID list
	Green Glowing	Authorised RFID Card is tapped while charging cable is connected
	Glow green for 30 secs	Authorised RFID Card is tapped while charging cable is not connected
	Blinks red for 3 times	Start/stop charging attempt with unauthorised RFID card
	Constant Yellow	Altered Firmware
	Constant Yellow	Communication error between Smart Board and Power Board
	Blinks Green 500msec ON 500msec OFF	Randomized Delay (Only UK)
	Blinks purple 3 seconds OFF 1,2 seconds ON	Master Slave communication failure External meter communication failure
	Constant Purple	DIm total current limit is reached
	Blue Glowing	G100 State 1 and State 2
	Constant Purple	G100 State 3

3 - DESCRIPTION

<p>Model Name</p>	<p><u>MODEL DESCRIPTION: EVC08*-AC***-*</u></p> <p>EVC08 : Electric Vehicle AC Charger</p> <p>1st Asterisk (*) : Cabinet Type</p> <p>01 : Liveo</p> <p>02 : Newnow</p> <p>2nd Asterisk (*) : Rated Power</p> <p>7 : 7.4 kW (1Phase Supply Equipment)</p> <p>11 : 11 kW (3Phase Supply Equipment)</p> <p>22 : 22 kW (3Phase Supply Equipment)</p> <p>3rd Asterisk (*) can include combinations of the following communication module options. High Secure Smart Board with Ethernet Port, Wi-Fi, RFID and NFC reader are standard equipment for all of the model variants. L and 5G options cannot be selected simultaneously.</p> <p>L : LTE / 3G / 2G module</p> <p>5G : 5G / LTE / 3G module</p> <p>P : ISO 15118 PLC module</p> <p>4th Asterisk (*) can be one of the following:</p> <p>Blank : No Display</p> <p>D : 4.3" TFT color display</p> <p>5th Asterisk (*) can be one of the following:</p> <p>Blank : No MID</p> <p>MID : Charging unit with MID meter.</p> <p>EICH : Charging Unit with Eichrecht Conformity</p> <p>6th Asterisk (*) can be one of the following:</p> <p>Blank : Case-B Connection with normal socket</p> <p>T2S : Case-B Connection with shuttered socket</p> <p>T2P : Case C Connection with Type-2 plug</p> <p>T1P : Case C Connection with Type-1 plug</p>
<p>Cabinet</p>	<p>EVC08</p>

4 - TECHNICAL SPECIFICATION

This product is compliant to IEC61851-1 (Ed3.0) and IEC61851-21-2 standard for Mode 3 use.

Model		EVC08-AC22 Series	EVC08-AC11 Series	EVC08-AC7 Series
IEC Protection class		Class - I		
Vehicle Interface	Socket Model	Socket TYPE 2 (IEC 62196)		
	Cable Model	Cable with TYPE 2 (IEC 62196) Female Plug		
Voltage and Current Rates		230/400V ~ 50 Hz - 3-Phase 32A	230/400V ~ 50 Hz - 3-Phase 16A	230 V ~ 50 Hz - 1-Phase 32A
Broken PEN Detection Voltage Range (Optional)		<208V , >254V Single/Three phase TN-C-S supplies only		
AC Maximum Charge Output		22kW	11kW	7.4kW
Built-in Residual Current Sensing module		6mA DC 4P- 40mA AC RCCB Type-A		
Required Circuit Breaker on AC Mains		4P-40A MCB Type-C	4P-20A MCB Type-C	2P-40A MCB Type-C
Required AC Mains Cable		5 x 6 mm ² (< 50 m) External Dimensions: Ø 18–25 mm	5 x 4 mm ² (< 50 m) External Dimensions: Ø 18–25 mm	3 x 6 mm ² (< 50 m) External Dimensions: Ø 13–18 mm
Required AC Mains Cable (Optionally only for France)		5 x 10 mm ² (< 50 m) External Dimensions: Ø 18–25 mm	5 x 6 mm ² (< 50 m) External Dimensions: Ø 18–25 mm	3 x 10 mm ² (< 50 m) External Dimensions: Ø 13–18 mm

5 - CONNECTIVITY

Ethernet	10/100 Mbps Ethernet
Wi-Fi	Wi-Fi 802.11 a/b/g/n/ac 2.4 GHz and 5 GHz
Bluetooth (Optional)	5.1 and 4.2 (low energy)
Cellular (Optional)	LTE / 3G / 2G LTE: B1 (2100 MHz), B3 (1800 MHz), B7 (2600 MHz), B8 (900 MHz), B20 (800 MHz), B28A (700 MHz) WCDMA: B1 (2100 MHz), B8 (900 MHz) GSM: B3 (1800 MHz), B8 (900 MHz)

6 - OTHER FEATURES (CONNECTED MODELS)

Diagnostics	Diagnostics over OCPP WebconfigUI
Software Update	Remote software update over OCPP WebconfigUI update Remote software update with server

7 - AUTHORIZATION

RFID	ISO-14443A/B and ISO-15693
PLUG & CHARGE (Optional)	ISO-15118-2

8 - MECHANICAL SPECIFICATIONS

Material	Plastic
Product size	260 mm (Width) x 350 mm (Height) x 158 mm (Depth)
Dimensions (with package)	365 mm (Width) x 495 mm (Height) x 320 mm (Depth) - (cable model) 365 mm x 495 mm x 295 mm - (socket model)
Product weight	5,5 kg for socket equipped model 9 kg for tethered cable model (3 phase) 7,5 kg for tethered cable model (1 phase)
Weight with package	7,6 kg for socket equipped model 12 kg for tethered cable model (3 phase) 10,5 kg for tethered cable model (1 phase)
AC Mains Cable Dimensions	For three-phase models Ø 18-25 mm For one-phase models Ø 13-18 mm
Cable Inlets	AC Mains / Ethernet / Modbus

9 - ENVIRONMENTAL TECHNICAL SPECIFICATIONS

Protection Class	Ingress Protection	IP54
	Impact Protection	IK10
Usage Conditions	Temperature	-25 °C to 50 °C
	Humidity	5% - 95% (relative humidity, without condensation)
	Altitude	0 - 3,000m

10 - CHARGING

Your charging station is configured to be used in authorized charging mode by default. Check authorized charging mode behavior details in below section.

10.1 - STANDALONE USAGE MODES

First usage of “Standalone Usage” mode charger: Your charger’s master RFID card is already registered to your charger and you can find the master RFID card in accessories. When your charger is powered in the first time, it opens in “onboarding” screens as shown figure below. If you do not make any configuration in onboarding screens for 60 seconds and connect your charging cable, your charging station starts in autostart mode automatically.

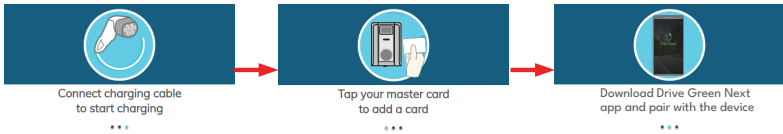

10.1.1 - AUTOSTART CHARGING MODE

Your charging station behaves in autostart charging mode as mentioned below:

- a) If you do not make any configuration in configuration mode for 60 seconds and connect your charging cable, your charging station starts in autostart mode automatically.
- b) If you delete the last RFID card from the local RFID card list, then your charger starts to behave as autostart mode.

10.1.1.1 - SOCKET EQUIPPED MODEL

10.1.1.1.1 - VEHICLE CONNECTION & CHARGING

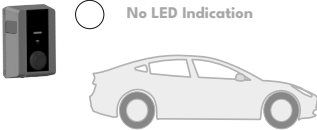
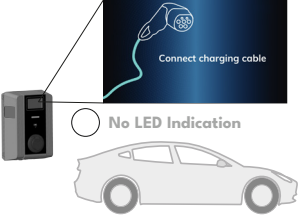
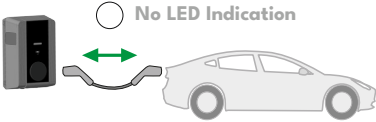
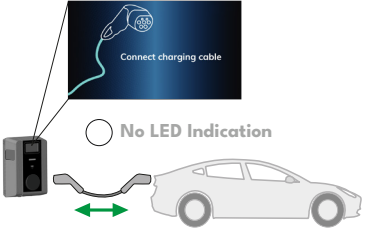
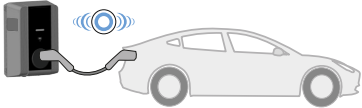
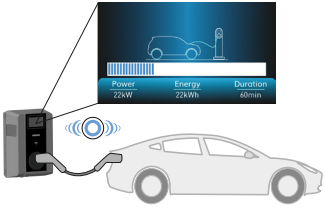

Model Without Display	Model With Display
<p>1 - Ensure that your vehicle and the station is ready for charging</p> 	<p>1 - Ensure that your vehicle and the station is ready for charging.</p> 
<p>2 - Insert the charging plug to the vehicle inlet and charging station socket outlet.</p> 	<p>2 - Insert the charging plug to the vehicle inlet and charging station socket outlet.</p> 
<p>3 - Charging starts and status indicator LED glows in blue.</p> 	<p>3 - Charging starts automatically, and status indicator LED glows in blue.</p> 

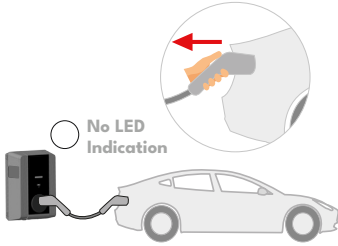
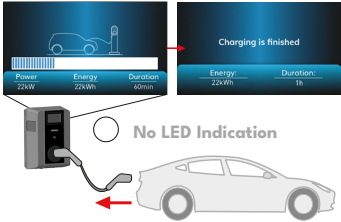
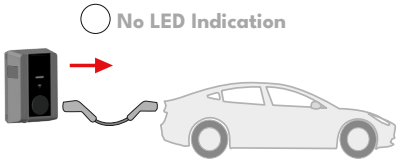
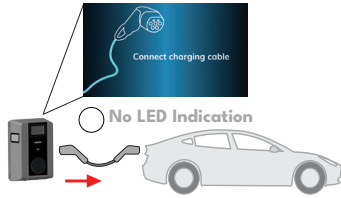
10.1.1.1.2 - STOP CHARGING

Model Without Display	Model With Display
<p>1- Unplug the charging cable from the vehicle first to stop charging. Do not attempt to remove the plug from the station before unplugging it from the vehicle. Otherwise locking mechanism may get damaged.</p> 	<p>1- Unplug the charging cable from the vehicle first to stop charging. Do not attempt to remove the plug from the station before unplugging it from the vehicle. Otherwise locking mechanism may get damaged.</p> 
<p>2 - Unplug the charging cable from the station.</p> 	<p>2 - Unplug the charging cable from the station.</p> 

10.1.1.2 - ATTACHED CABLE MODEL

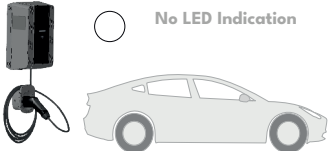
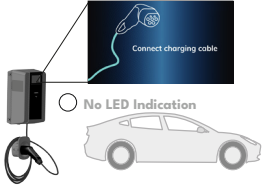
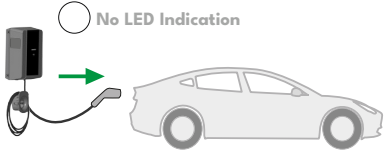
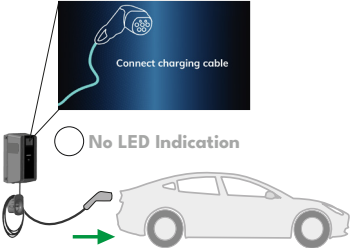
10.1.1.2.1 - VEHICLE CONNECTION & CHARGING

Model Without Display	Model With Display
<p>1 - Ensure that your vehicle and the station is ready for charging.</p> 	<p>1 - Ensure that your vehicle and the station is ready for charging.</p> 
<p>2 - Insert the charging plug to the vehicle inlet and charging station socket outlet.</p> 	<p>2 - Insert the charging plug to the vehicle inlet and charging station socket outlet.</p> 
<p>3 - Charging starts automatically, and status indicator LED glows in blue.</p> 	<p>3 - Charging starts automatically, and status indicator LED glows in blue.</p> 

10.1.1.2.2 - STOP CHARGING

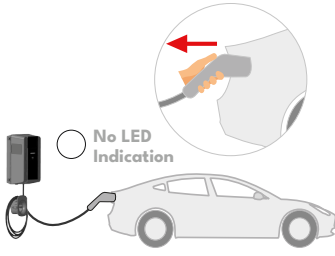
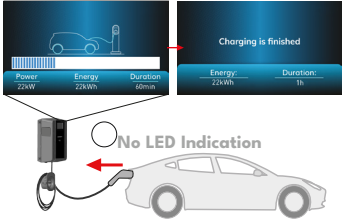
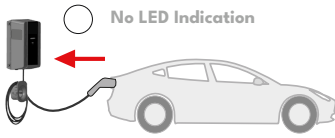
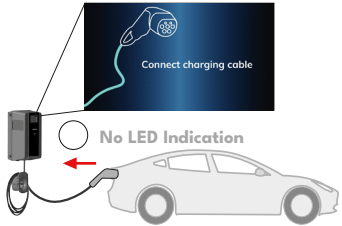
Model Without Display	Model With Display
<p>1- Unplug the charging cable from the vehicle first to stop charging.</p> 	<p>1- Unplug the charging cable from the vehicle first to stop charging.</p> 
<p>2 - Insert the charging plug to the charging plug holder of the station.</p> 	<p>2 - Insert the charging plug to the charging plug holder of the station.</p> 

NOTE : If you delete the last RFID card from the local RFID card list, then your charger starts to behave as autostart mode.

10.1.2 - RFID AUTHORIZED MODE

10.1.2.1 - REGISTERING USER RFID CARD

In standalone usage mode, the master RFID card is already registered to your charger. If you tap the master RFID card to your charging station when the charging cable is not connected, your charger starts to make broadcasting over Bluetooth and also in the same time you can add user RFID card to the charger's local RFID list. In this period of time, indication LED starts to blink blue for 60 seconds. You can add/delete your user RFID card. If you do not make any configuration in 60 seconds, charging station exists from configuration mode and returns to its previous mode.

10.1.2.1.1 - ADD/DELETE RFID CARD TO/FROM LOCAL RFID LIST:



As mentioned above, in configuration mode within 60 seconds, if you tap any user RFID card which is not in Local RFID list, it is provided to add to the list. Similarly, if you tap the user RFID card which was already added to the local RFID list before, then it is deleted from the list. If you delete the last RFID card from the local RFID card list, then your charger starts to behave as autostart mode.

10.1.2.2 - VEHICLE CONNECTION & CHARGING

10.1.2.2.1 - SOCKET EQUIPPED MODEL

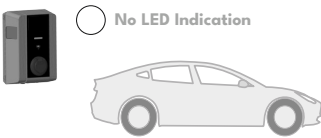
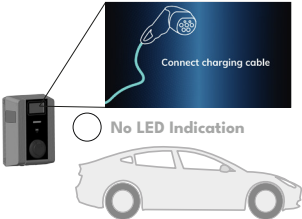
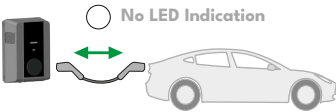
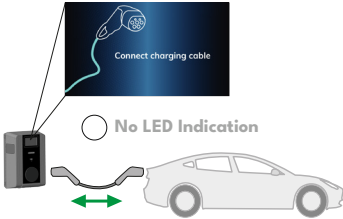
10.1.2.2.1.1 - VEHICLE CONNECTION & CHARGING

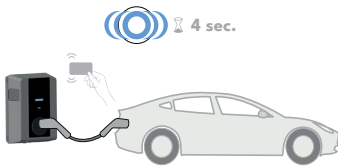
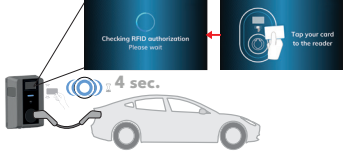
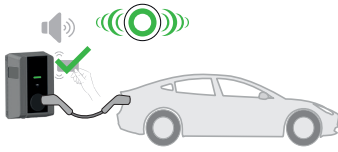
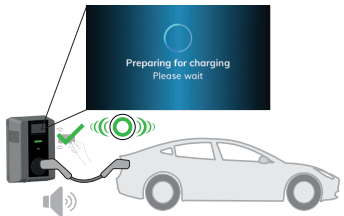
Model Without Display	Model With Display
<p>1 - Ensure that your vehicle and the station is ready for charging.</p> 	<p>1 - Ensure that your vehicle and the station is ready for charging.</p> 
<p>2 - Insert the charging plug to the vehicle inlet and charging station socket outlet.</p> 	<p>2 - Insert the charging plug to the vehicle inlet and charging station socket outlet.</p> 

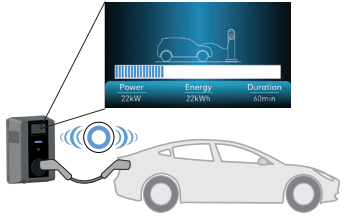
<p>3- Tap the user RFID card to the reader.</p> 	<p>3- Tap the user RFID card to the reader.</p> 
<p>4- You may start charging with a card that has been authorized before.</p> 	<p>4- You may start charging with a card that has been authorized before.</p> 
<p>5 - Charging starts and status indicator LED glows in blue.</p> 	<p>5 - Charging starts and status indicator LED glows in blue.</p> 

NOTE : Charging operation is rejected by the charging station when you want to start charging with an unauthorized card. It takes around one minute to reboot your charging station after it resets.

10.1.2.2.1.2 - STOP CHARGING

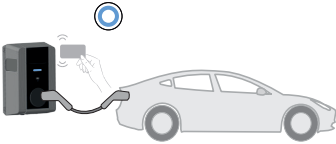
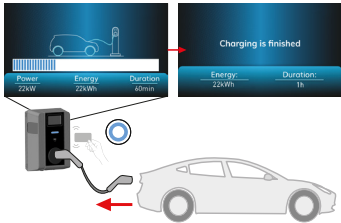
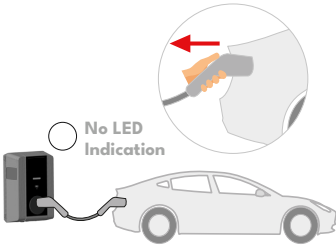
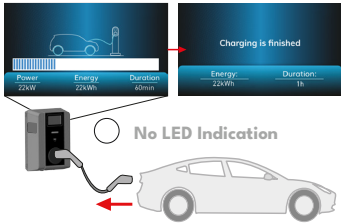
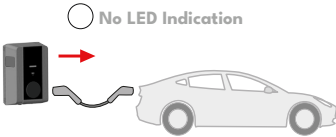
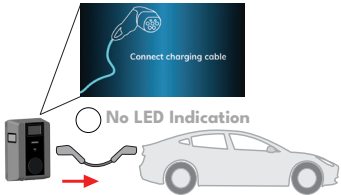
Model Without Display	Model With Display
<p>1- You may follow the alternative methods specified below to stop charging. Do not attempt to unplug the charging cable from the station before stopping charging otherwise locking mechanism may get damaged.</p>	<p>1- You may follow the alternative methods specified below to stop charging. Do not attempt to unplug the charging cable from the station before stopping charging otherwise locking mechanism may get damaged.</p>
<p>Method1. You can terminate charging by tapping the RFID card that you have started charging before.</p> 	<p>Method1. You can terminate charging by tapping the RFID card that you have started charging before.</p> 
<p>Method2. You may stop charging by unplugging the charging from the vehicle first.</p> 	<p>Method2. You may stop charging by unplugging the charging cable from the vehicle first.</p> 
<p>2 - Unplug the charging cable from the station.</p> 	<p>2 - Unplug the charging cable from the station.</p> 

10.1.2.2.2 - ATTACHED CABLE MODEL**10.1.2.2.2.1 - VEHICLE CONNECTION & CHARGING**

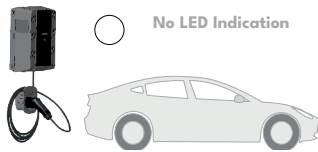
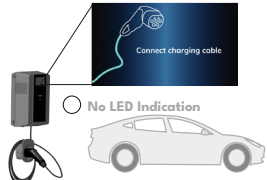
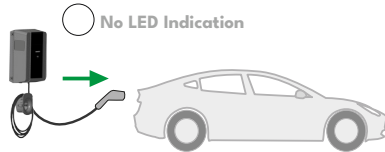
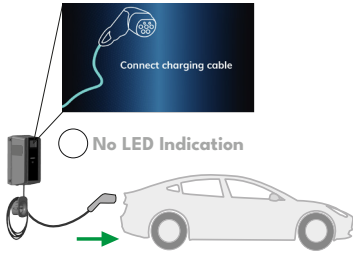
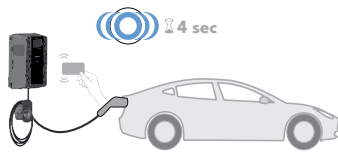
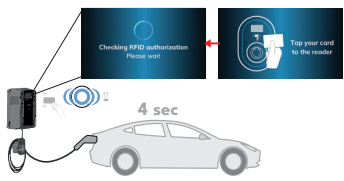
Model Without Display	Model With Display
<p>1 - Ensure that your vehicle and the station is ready for charging.</p> 	<p>1 - Ensure that your vehicle and the station is ready for charging.</p> 
<p>2 - Insert the charging plug to the vehicle inlet.</p> 	<p>2 - Insert the charging plug to the vehicle inlet.</p> 
<p>3- Tap the RFID card to the RFID reader.</p> 	<p>3- Tap the user RFID card to the reader.</p> 

4- You may start charging with a card that has been authorized before.

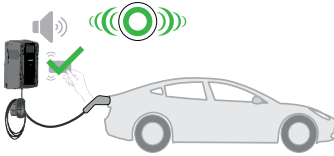

4- You may start charging with a card that has been authorized before.

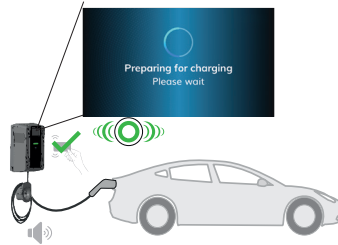

5 - Charging starts and status indicator LED glows in blue.



5 - Charging starts and status indicator LED glows in blue.



NOTE: Charging operation is rejected by the charging station when you want to start charging with an unauthorized card. It takes around one minute to reboot your charging station after it resets.

10.1.2.2.2.2 - STOP CHARGING

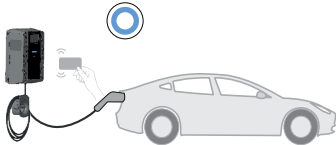
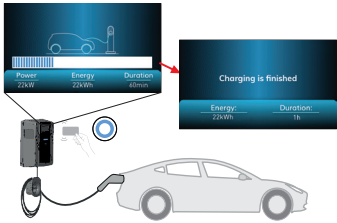
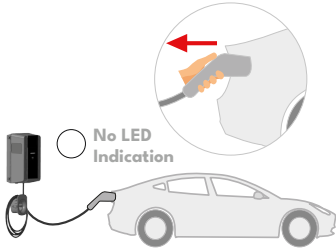
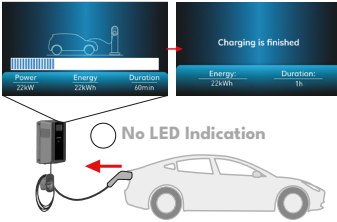
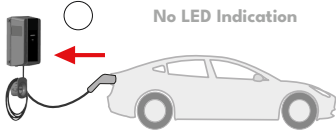
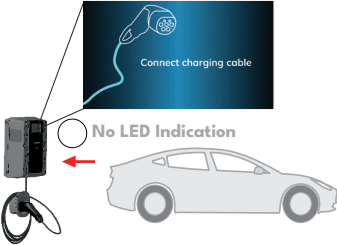
Model Without Display	Model With Display
<p>1- You may follow the alternative methods specified below to stop charging.</p> <p>Method1. You can terminate charging by tapping the RFID card that you have started charging before.</p> 	<p>1- You may follow the alternative methods specified below to stop charging.</p> <p>Method1. You can terminate charging by tapping the RFID card that you have started charging before.</p> 
<p>Method2. You may stop charging by unplugging the charging from the vehicle first.</p> 	<p>Method2. You may stop charging by unplugging the charging cable from the vehicle.</p> 
<p>2- Insert the charging plug to the dummy socket of the station.</p> 	<p>2- Insert the charging plug to the charging plug holder of the station.</p> 

10.1.3 - SMART APPLICATION AUTHORIZED MODE (Optional with Wi-Fi)

10.1.3.1 - CONFIGURING DRIVE GREEN APPLICATION

In standalone usage mode, the master RFID card is already registered to your charger. If you tap the master RFID card to your charging station when the charging cable is not connected, your charger starts to make broadcasting over Bluetooth. In this period of time, indication LED starts to blink blue for 60 seconds. You can configure Drive Green application from your smartphone in this period of time. If you do not make any configuration in 60 seconds, charging station exits from configuration mode and returns to its previous mode.

10.1.3.2 - DRIVE GREEN CONFIGURATION

It is waited to start configuration from your smartphone within 60 seconds after the configuration mode starts. If you do not make any configuration in 60 seconds, bluetooth broadcasting finishes and configuration mode ends.

Please download “Drive Green Next” application from Android Play Store or iOS App Store.

You can reach to the application by QR code below.



Open Drive Green Mobile App. You will see selection of different models. To configure your charger, select EVC08 model shown in picture above and click continue button and follow the instructions which are mentioned inside the application in detail to setup the charger and finish the configuration. Please note that after first configuration your EV charger and Mobile Application connect locally via Bluetooth, so you can only monitor and control your charging session when you are near the charging station. If you want to monitor and control your charging station from the Internet remotely, you need to configure Internet connection settings of your EV charger from “Connectivity” tab in “Device Settings” menu. You can either use Ethernet LAN connectivity or WiFi WLAN connectivity option.

10.1.3.3 - VEHICLE CONNECTION & CHARGING

After configuring your charger with smart application, you can control the charger via the application either in autostart mode or in RFID authorised mode. Autostart and RFID authorised modes are explained.

Your charging station behaves in autostart charging mode as mentioned below. But you can continue to control the charger with smart application even it is in autostart charging mode.

- a) If you do not make any configuration in configuration mode for 60 seconds and connect your charging cable, your charging station starts in autostart mode automatically.
- b) If you delete the last RFID card from the local RFID card list, then your charger starts to behave as autostart mode.

10.1.3.3.1 - SOCKET EQUIPPED MODEL

10.1.3.3.1.1 - VEHICLE CONNECTION & CHARGING

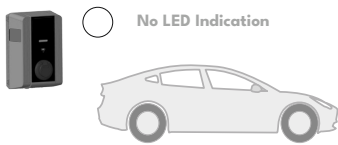
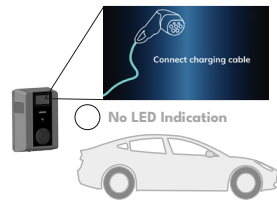
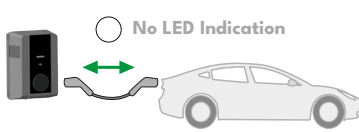
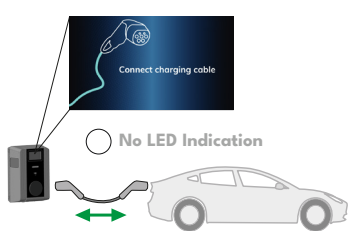
Model Without Display	Model With Display
<p>1 - Ensure that your vehicle and the station is ready for charging.</p> 	<p>1 - Ensure that your vehicle and the station is ready for charging.</p> 
<p>2 - Insert the charging plug to the vehicle inlet and charging station socket outlet.</p> 	<p>2 - Insert the charging plug to the vehicle inlet and charging station socket outlet.</p> 

3- Tap the user RFID reader or press “Charge Now” button from the application.



3- Tap the user RFID reader or press “Charge Now” button from the application.

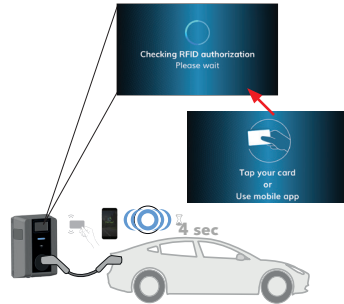

4- You may start charging with a card that has been authorized before or after pressing “Charge Now” button in mobile application.



4- You may start charging with a card that has been authorized before or after pressing “Charge Now” button in mobile application.

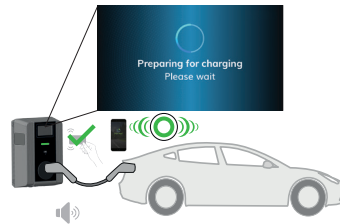

5 - Charging starts and status indicator LED glows in blue.

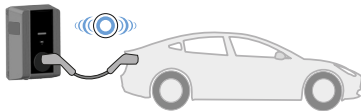

5 - Charging starts and status indicator LED glows in blue.

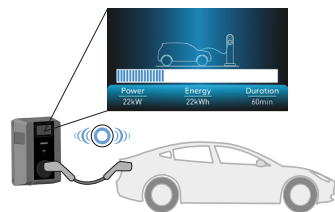

NOTE : Charging operation is rejected by the charging station when you want to start charging with an unauthorized card. It takes around one minute to reboot your charging station after it resets.

10.1.3.3.1.2 - STOP CHARGING

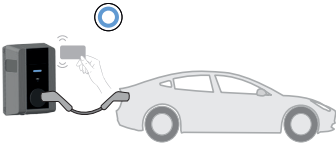
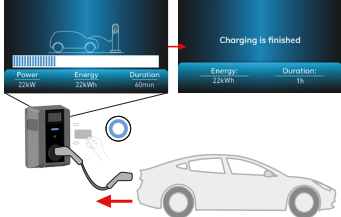
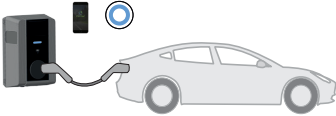
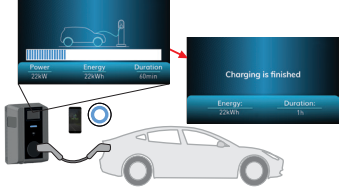
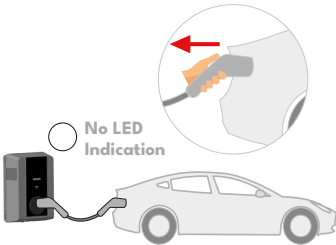
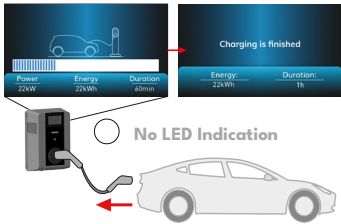
Model Without Display	Model With Display
<p>1- You may follow the alternative methods specified below to stop charging. Do not attempt to unplug the charging cable from the station before stopping charging otherwise locking mechanism may get damaged.</p>	<p>1- You may follow the alternative methods specified below to stop charging. Do not attempt to unplug the charging cable from the station before stopping charging otherwise locking mechanism may get damaged.</p>
<p>Method1. You can terminate charging by tapping the RFID card that you have started charging before.</p> 	<p>Method1. You can terminate charging by tapping the RFID card that you have started charging before.</p> 
<p>Method2. You may stop charging by pressing “STOP” button in mobile application in your smartphone.</p> 	<p>Method2. You may stop charging by pressing “STOP” button in mobile application in your smartphone.</p> 
<p>Method3. You may stop charging by unplugging the charging from the vehicle first.</p> 	<p>Method3. You may stop charging by unplugging the charging cable from the vehicle.</p> 

2 - Unplug the charging cable from vehicle first and then from your charging station.

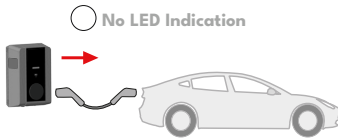

2 - Unplug the charging cable from vehicle first and then from your charging station.

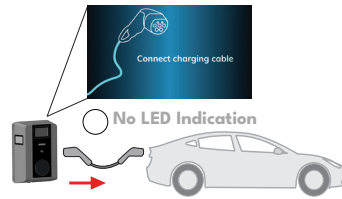

10.1.3.3.2 - ATTACHED CABLE MODEL

10.1.3.3.2.1 - VEHICLE CONNECTION & CHARGING

Model Without Display

1 - Ensure that your vehicle and the station is ready for charging.

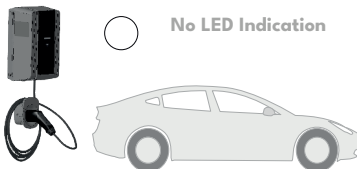

Model With Display

1 - Ensure that your vehicle and the station is ready for charging.

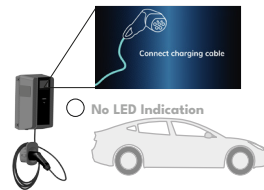

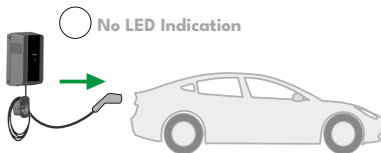

2 - Insert the charging plug to the vehicle inlet.

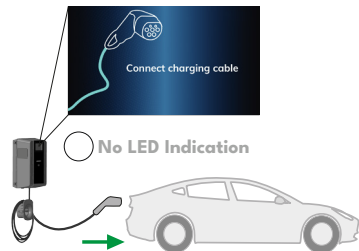

2 - Insert the charging plug to the vehicle inlet.

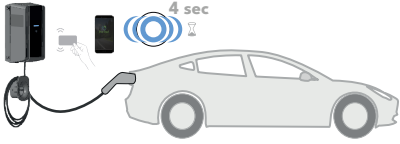
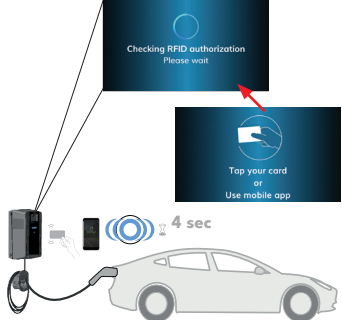
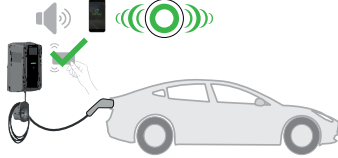
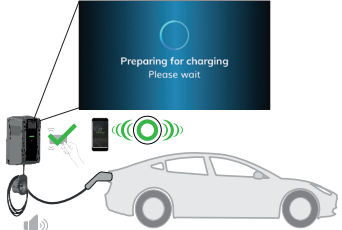

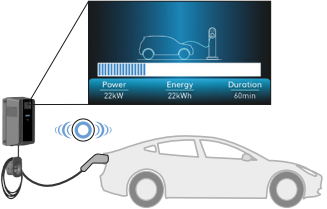
<p>3- Tap the user RFID reader or press “Charge Now” button from the application.</p> 	<p>3- Tap the user RFID reader or press “Charge Now” button from the application.</p> 
<p>4- You may start charging with a card that has been authorized before or after pressing “Charge Now” button in mobile application.</p> 	<p>4- You may start charging with a card that has been authorized before or after pressing “Charge Now” button in mobile application.</p> 
<p>5 - Charging starts automatically, and status indicator LED glows in blue.</p> 	<p>5 - Charging starts and status indicator LED glows in blue.</p> 

NOTE: Charging operation is rejected by the charging station when you want to start charging with an unauthorized card. It takes around one minute to reboot your charging station after it resets.

10.1.3.3.2.2 - STOP CHARGING

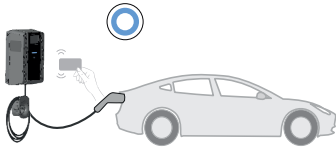
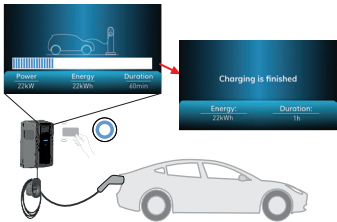
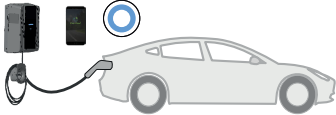
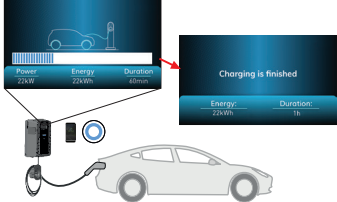
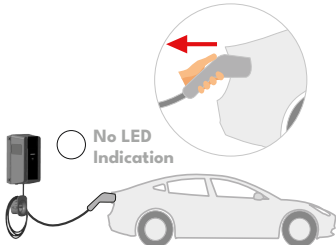
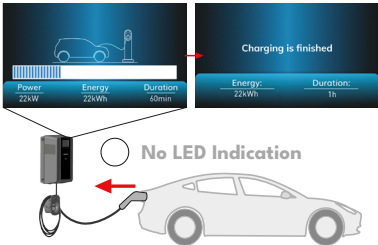
Model Without Display	Model With Display
<p>1- You may follow the alternative methods specified below to stop charging.</p>	<p>1- You may follow the alternative methods specified below to stop charging.</p>
<p>Method1. You can terminate charging by tapping the RFID card that you have started charging before.</p> 	<p>Method1. You can terminate charging by tapping the RFID card that you have started charging before.</p> 
<p>Method2. You may stop charging by pressing “STOP” button in mobile application in your smartphone.</p> 	<p>Method2. You may stop charging by pressing “STOP” button in mobile application in your smartphone.</p> 
<p>Method3. You may stop charging by unplugging the charging from the vehicle first.</p> 	<p>Method3. You may stop charging by unplugging the charging cable from the vehicle.</p> 

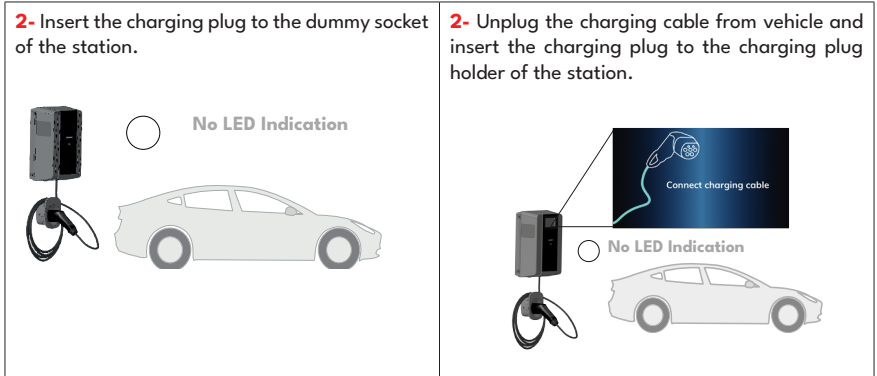

10.1.3.4 - APPLICATION MODES

10.1.3.4.1 - ECO CHARGE MODE

Eco Charge mode is a function which the user can set according the peak hours of electricity usage in his/her country and manage the charging periods accordingly. When Eco Charge is activated, charging start and finish intervals can be set.

If the charger starts charging in between the eco time interval set by the user, charging starts and finishes normally. If the charging starts out of eco time interval set by the user, it is waited to be in eco time period to start charging.

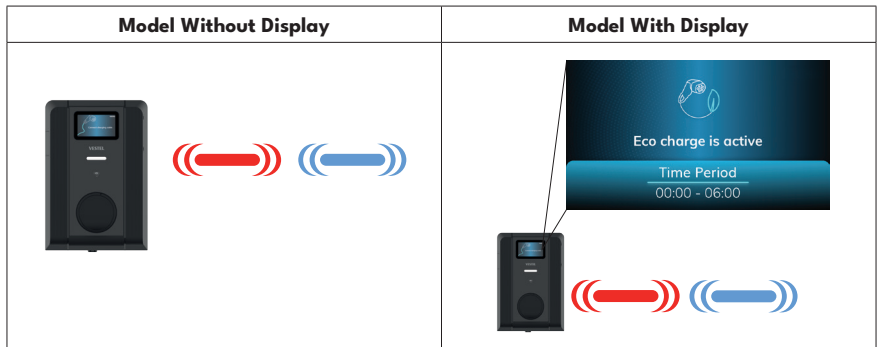

- If your charger is RFID authorised, after the charging cable is connected, you need to press “Charge Now” button from the application or tap one of the user card which is authorised. After that it is passed to eco time waiting mode.
- If you need to charge your EV without waiting the eco time interval, you can press to “Charge Now” button in your application for or tap one of authorised RFID user cards for immediate charging start.
- Your charger starts to blink blue-red when it waits the eco-time interval.
- When the charger starts to wait the eco charge interval, in the first 5 minutes, indication LED blinks blue and red colours. After 5 minutes the LED stops blinking blue and red colours. Similarly when

the eco charge interval finishes, charging section pauses and indication LED blinks blue and red colours. After 5 minutes, the LED stops blinking.

If you want your electric vehicle to continue charging after Eco Charge interval finishes, you can activate this functionality in the “Schedule Charge” tab in “Continue After Eco Charge” menu.

10.1.3.4.2 - DELAY CHARGE FUNCTION

Your charger has function to start your charging in a delay which you set in the application from your smartphone. To start charging in delay mode;

- After you connect the charging cable and set the delay time period from your application and press “Delay Charge” button, the charger passes to delay time mode, charging cable is locked by the charger and the indication LED starts to blink blue-red.
- In your application screen, you can see that the charging station is in delay charge mode.
- If you want to start immediate charging without waiting the delay time period; even the delay time is active from the application,
 - a) For RFID authorised mode device, any authorised RFID card tapping or pressing “Charge Now” button from the application can let your charger to start charging immediately.
 - b) For autostart mode device, pressing charge “Charge Now” button from the application can let your charger to start charging immediately.
- Delay charge screen in your charging station will be as below.
- When the charger is set as delay charging mode, in the first 5 minutes, indication LED blinks blue and red colours. After 5 minutes the LED stops blinking blue and red colours.

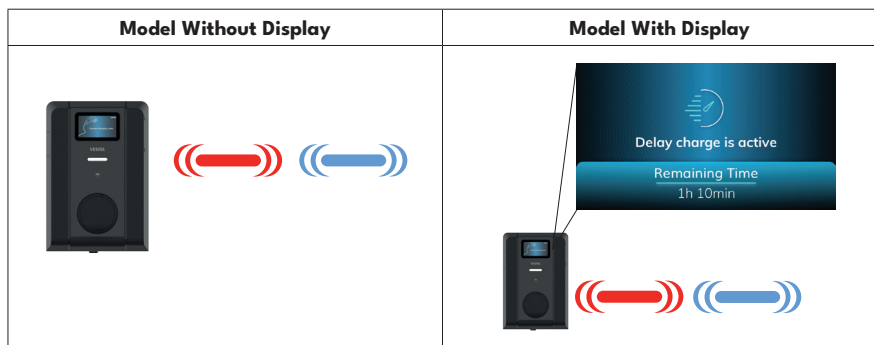

10.1.3.4.3 - LOCKABLE CABLE FUNCTION

For socket equipped models, it is possible to fix the charging cable to the charging station by locking the socket interlock permanently. This feature can be activated from lockable cable function in the “Advanced Settings” tab in “Device Settings” menu.

10.1.3.4.4 - MASTER AND USER RFID CARD RESET

Master and user RFID card lists can be cleared in master and user cards menu in “Advanced Settings” tab. When you reset user RFID card list, the charging station may become plug and charge mode according to “Free Charging” setting.

When you reset master RFID card you need to tap new master RFID card to the reader. If you don't tap new master RFID card to the reader in specified time interval, the former master RFID card keeps its validity.

10.1.3.4.5 - POWER OPTIMIZER SETTINGS

This feature is provided with an optional metering accessories which are sold separately. In power optimizer mode, the total current drawn from the main switch of the house by charging station and other household appliances is measured with current sensor integrated to the main power line as show in figure below. Power Optimizer feature and maximum current limit of the main power line of the system is set from “Power Optimizer” setting in “Advanced Settings” tab in “Device Settings” menu.

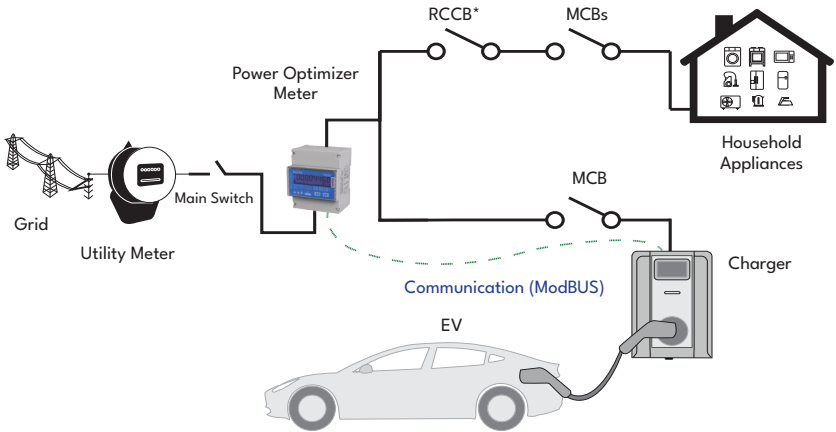

Visual representation is provided



10.1.4 - RFID LOCAL LIST AUTHORIZED MODE & ACCEPT ALL RFIDS MODE

Please check "STANDALONE MODE SETTINGS" in Installation Guide document.

10.1.4.1 - SOCKET EQUIPPED MODEL

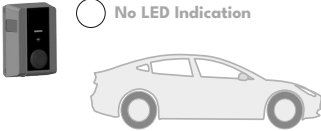
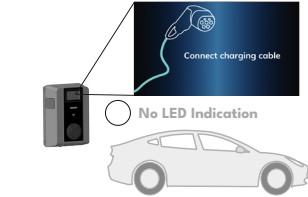
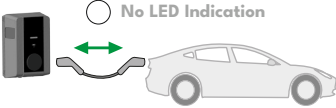
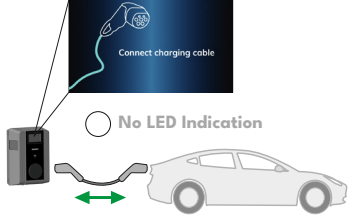
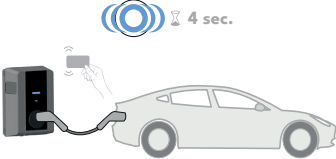
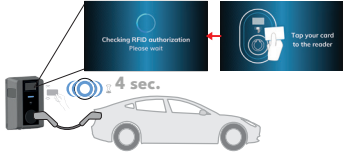
10.1.4.1.1 - VEHICLE CONNECTION & CHARGING

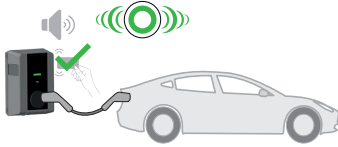
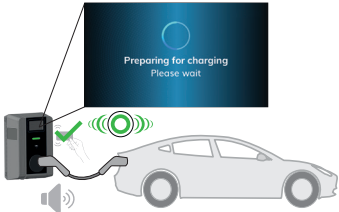
Model Without Display	Model With Display
<p>1 - Ensure that your vehicle and the station is ready for charging.</p> 	<p>1 - Ensure that your vehicle and the station is ready for charging.</p> 
<p>2 - Insert the charging plug to the vehicle inlet and charging station socket outlet.</p> 	<p>2 - Insert the charging plug to the vehicle inlet and charging station socket outlet.</p> 
<p>3 - Tap the user RFID card to the reader.</p> 	<p>3 - Tap the user RFID card to the reader.</p> 

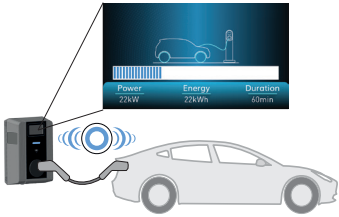
<p>4- You may start charging with a card that has been authorized before, if the charging station is in RFID Local List Authorized Mode.</p> <p>If the charging station is in Accept ALL RFIDs Mode, then you may start charging with any supported RFID card.</p> 	<p>4- You may start charging with a card that has been authorized before, if the charging station is in RFID Local List Authorized Mode.</p> <p>If the charging station is in Accept ALL RFIDs Mode, then you may start charging with any supported RFID card.</p> 
<p>5- Charging starts and status indicator LED glows in blue.</p> 	<p>5- Charging starts and status indicator LED glows in blue.</p> 

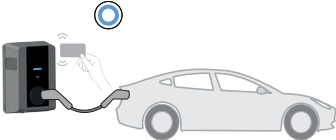
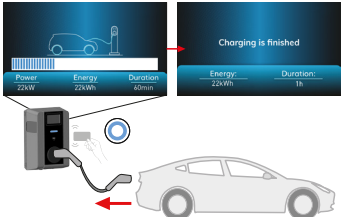
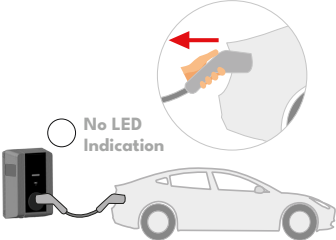
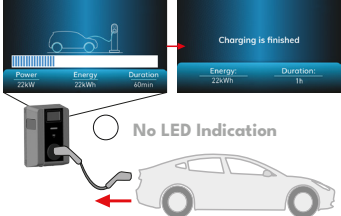
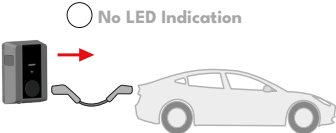
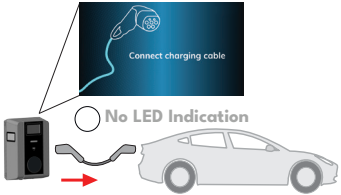

NOTE : Charging operation is rejected by the charging station when you want to start charging with an unauthorized card. It takes around one minute to reboot your charging station after it resets.

10.1.4.1.2 - STOP CHARGING

Model Without Display	Model With Display
<p>1- You may follow the alternative methods specified below to stop charging. Do not attempt to unplug the charging cable from the station before stopping charging otherwise locking mechanism may get damaged.</p>	<p>1- You may follow the alternative methods specified below to stop charging. Do not attempt to unplug the charging cable from the station before stopping charging otherwise locking mechanism may get damaged.</p>
<p>Method1. You can terminate charging by tapping the RFID card that you have started charging before.</p> 	<p>Method1. You can terminate charging by tapping the RFID card that you have started charging before.</p> 
<p>Method2. You may stop charging by unplugging the charging cable from the vehicle first.</p>  <p>No LED Indication</p>	<p>Method2. You may stop charging by unplugging the charging cable from the vehicle first.</p>  <p>No LED Indication</p>
<p>2- Unplug the charging cable from the station.</p>  <p>No LED Indication</p>	<p>2- Unplug the charging cable from the station.</p>  <p>No LED Indication</p>

10.1.4.2 - ATTACHED CABLE MODEL

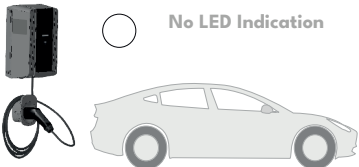
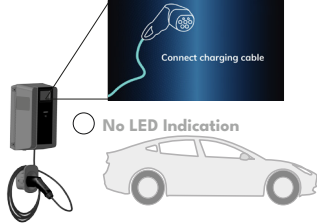
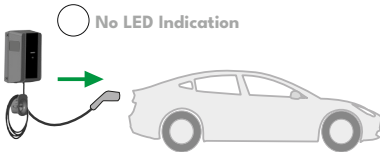
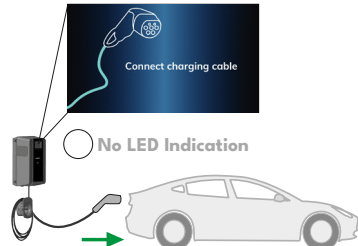
10.1.4.2.1 - VEHICLE CONNECTION & CHARGING

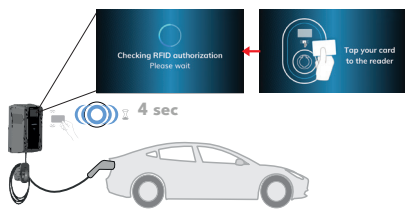
Model Without Display	Model With Display
<p>1 - Ensure that your vehicle and the station is ready for charging.</p> 	<p>1 - Ensure that your vehicle and the station is ready for charging.</p> 
<p>2 - Insert the charging plug to the vehicle inlet.</p> 	<p>2 - Insert the charging plug to the vehicle inlet.</p> 
<p>3 - Tap the RFID card to the RFID reader.</p> 	<p>3 - Tap the RFID card to the RFID reader.</p> 

4- You may start charging with a card that has been authorized before, if the charging station is in RFID Local List Authorized Mode.

If the charging station is in Accept ALL RFIDs Mode, then you may start charging with any supported RFID card.

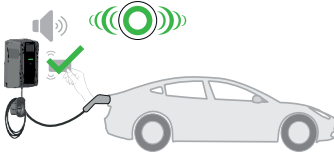

4- You may start charging with a card that has been authorized before, if the charging station is in RFID Local List Authorized Mode.

If the charging station is in Accept ALL RFIDs Mode, then you may start charging with any supported RFID card.

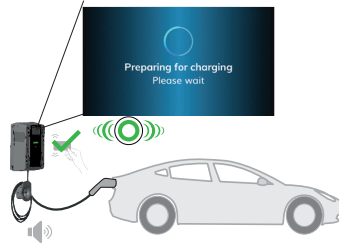

5 - Charging starts and status indicator LED glows in blue.

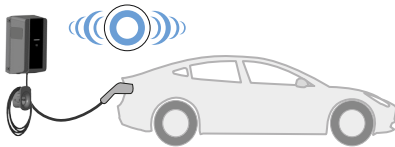

5 - Charging starts and status indicator LED glows in blue.

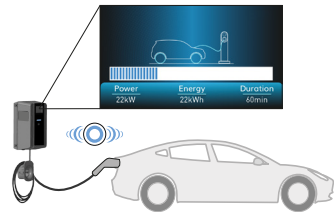

NOTE : Charging operation is rejected by the charging station when you want to start charging with an unauthorized card. It takes around one minute to reboot your charging station after it resets.

10.1.4.2.2 - STOP CHARGING

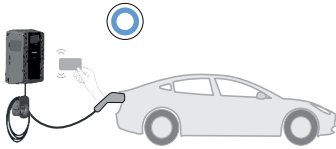
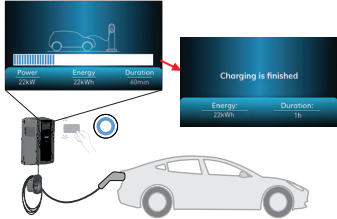
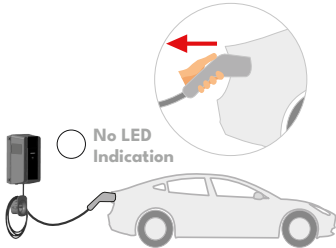
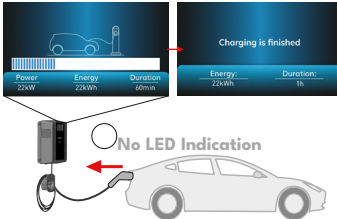
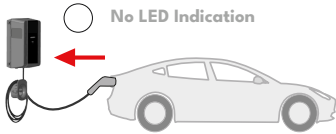
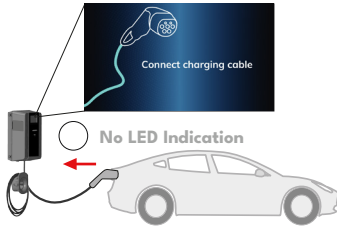
Model Without Display	Model With Display
<p>1- You may follow the alternative methods specified below to stop charging.</p>	<p>1- You may follow the alternative methods specified below to stop charging.</p>
<p>Method1. You can terminate charging by tapping the RFID card that you have started charging before.</p> 	<p>Method1. You can terminate charging by tapping the RFID card that you have started charging before.</p> 
<p>Method2. You may stop charging by unplugging the charging cable from the vehicle.</p>  <p>No LED Indication</p>	<p>Method2. You may stop charging by unplugging the charging cable from the vehicle.</p>  <p>No LED Indication</p>
<p>2- Insert the charging plug to the charging plug holder of the station.</p>  <p>No LED Indication</p>	<p>2- Insert the charging plug to the charging plug holder of the station.</p>  <p>No LED Indication</p>

10.2 - OCPP CENTRAL SYSTEM CONNECTED MODE (OPTIONAL)

10.2.1 - SOCKET EQUIPPED MODEL

10.2.1.1 - VEHICLE CONNECTION & CHARGING

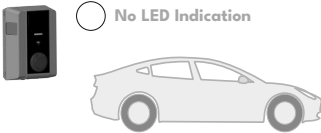
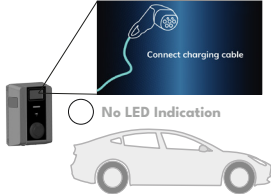
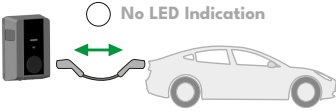
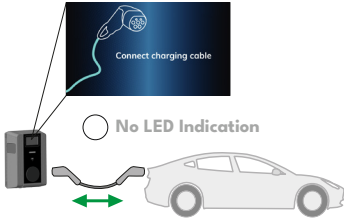
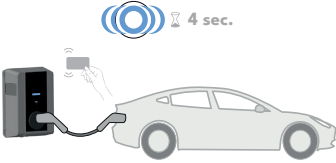
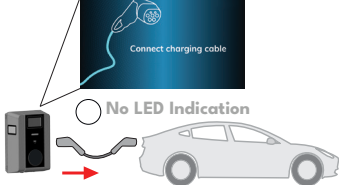
Model Without Display	Model With Display
<p>1 - Ensure that your vehicle and the station is ready for charging.</p> 	<p>1 - Ensure that your vehicle and the station is ready for charging.</p> 
<p>2 - Insert the charging plug to the vehicle inlet and charging station socket outlet.</p> 	<p>2 - Insert the charging plug to the vehicle inlet and charging station socket outlet.</p> 
<p>3- Tap the RFID card to the RFID reader you may start charging with a card which is provided by your charging operator.</p> 	<p>3- Tap the RFID card to the RFID reader you may start charging with a card which is provided by your charging operator.</p> 

4- You may start charging with a card that has been authorized before. If the RFID Card is authorized by OCPP Central System, charging will start.

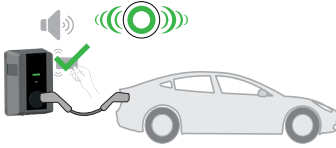

4- You may start charging with a card that has been authorized before. If the RFID Card is authorized by OCPP Central System, charging will start.



5 - Charging starts and status indicator LED glows in blue.



5 - Charging starts and status indicator LED glows in blue.

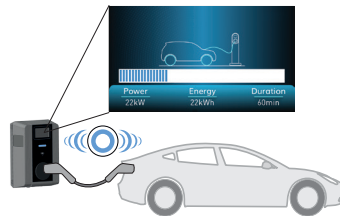

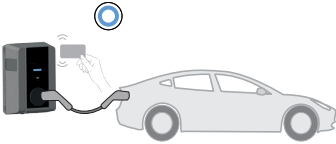
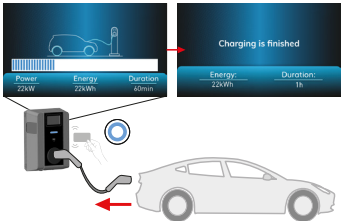
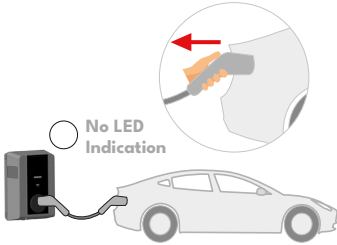
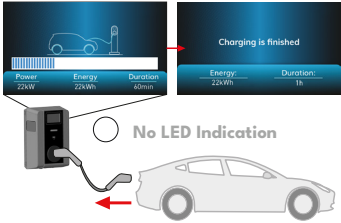
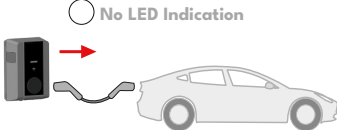
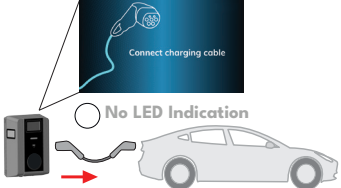

NOTE : Charging operation is rejected by the charging station when you want to start charging with an unauthorized card. It takes around one minute to reboot your charging station after it resets.

10.2.1.2 - STOP CHARGING

Model Without Display	Model With Display
<p>1- You may follow the alternative methods specified below to stop charging. Do not attempt to unplug the charging cable from the station before stopping charging otherwise locking mechanism may get damaged.</p>	<p>1- You may follow the alternative methods specified below to stop charging. Do not attempt to unplug the charging cable from the station before stopping charging otherwise locking mechanism may get damaged.</p>
<p>Method1. You can terminate charging by tapping the RFID card that you have started charging before.</p> 	<p>Method1. You can terminate charging by tapping the RFID card that you have started charging before.</p> 
<p>Method2. You may stop charging by unplugging the charging from the vehicle first.</p>  <p>No LED Indication</p>	<p>Method2. You may stop charging by unplugging the charging cable from the vehicle first.</p>  <p>No LED Indication</p>
<p>2 - Unplug the charging cable from the station.</p>  <p>No LED Indication</p>	<p>2 - Unplug the charging cable from the station.</p>  <p>No LED Indication</p>

10.2.2 - ATTACHED CABLE MODEL

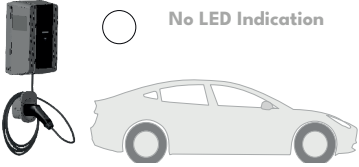
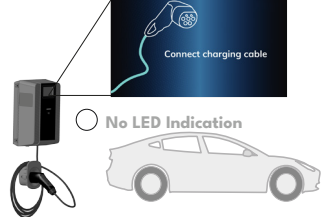
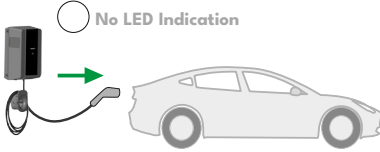
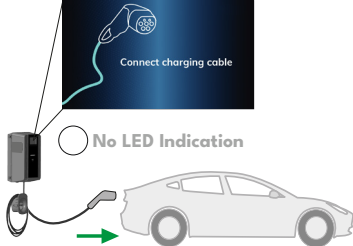
10.2.2.1 - VEHICLE CONNECTION & CHARGING

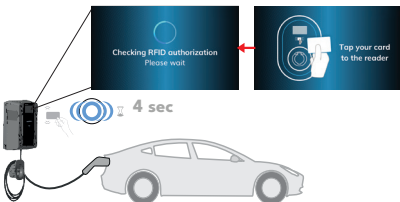
Model Without Display	Model With Display
<p>1 - Ensure that your vehicle and the station is ready for charging.</p> 	<p>1 - Ensure that your vehicle and the station is ready for charging.</p> 
<p>2 - Insert the charging plug to the vehicle inlet.</p> 	<p>2 - Insert the charging plug to the vehicle inlet.</p> 
<p>3 - Tap the RFID card to the RFID reader. You may start charging with a card which is provided by your charging operator.</p> 	<p>3 - Tap the RFID card to the RFID reader. You may start charging with a card which is provided by your charging operator.</p> 

4- You may start charging with a card that has been authorized before. If the RFID Card is authorized by OCPP Central System, charging will start.

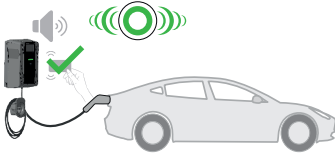

4- You may start charging with a card that has been authorized before. If the RFID Card is authorized by OCPP Central System, charging will start.

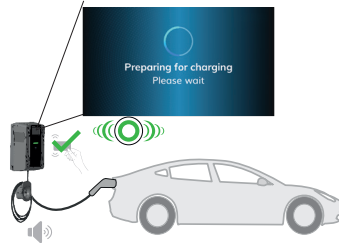

5 - Charging starts and status indicator LED glows in blue.

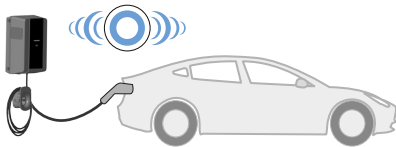

5 - Charging starts and status indicator LED glows in blue.

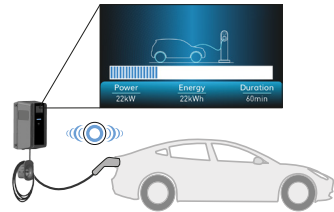

NOTE : Charging operation is rejected by the charging station when you want to start charging with an unauthorized card. It takes around one minute to reboot your charging station after it resets.

10.2.2.2 - STOP CHARGING

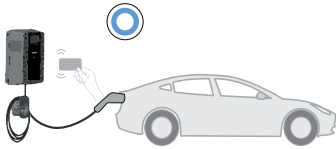
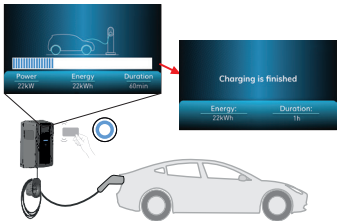
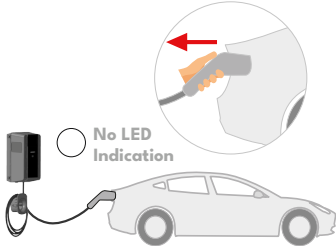
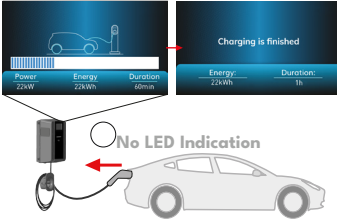
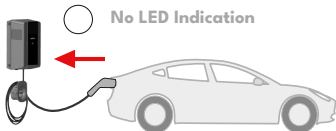
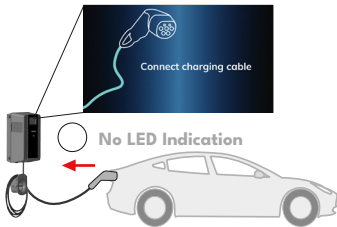
Model Without Display	Model With Display
<p>1- You may follow the alternative methods specified below to stop charging.</p> <p>Method1. You can terminate charging by tapping the RFID card that you have started charging before.</p> 	<p>1- You may follow the alternative methods specified below to stop charging.</p> <p>Method1. You can terminate charging by tapping the RFID card that you have started charging before.</p> 
<p>Method2. You may stop charging by unplugging the charging from the vehicle first.</p> 	<p>Method2. You may stop charging by unplugging the charging cable from the vehicle.</p> 
<p>2- Insert the charging plug to the dummy socket of the station.</p> 	<p>2- Insert the charging plug to the charging plug holder of the station.</p> 

All products images are given for as a representative.

10.2.3 - OCPP 1.6 JSON ADDITIONAL FEATURES

10.2.3.1 - RESERVATION FEATURE

Reservation feature allows the user to reserve the charging station for a period of time. During this period:

- The LED will blink in red and blue.
- Only the RFID card that is used for reservation may initiate the charging process. Other cards are rejected.

If charging is not initiated until the reservation period is expired, the LED will switch to “No Light Indication” mode.

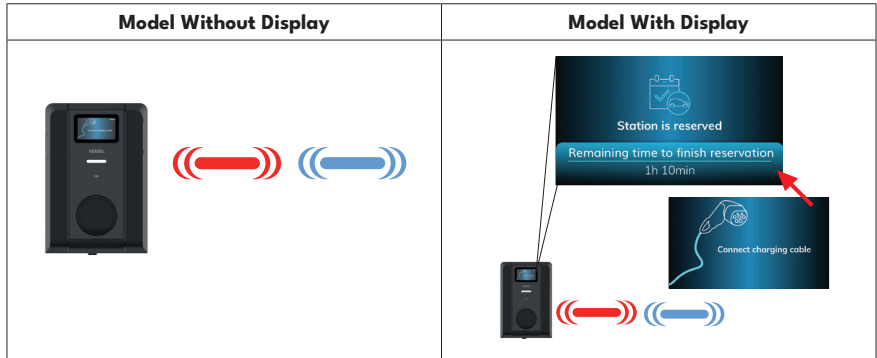

10.2.3.2 - REMOTE CHARGE INITIATION / TERMINATION

This feature is supported by the charging station. If it is also supported by the connected server, then charging process may be initiated/terminated remotely.

10.2.3.3 - HARD RESET/ SOFT RESET

If the electric vehicle charging station is not working properly, the service provider may restart the appliance with this feature. There are two types of restart. Software or hardware reset may be selected.

10.2.3.4 - UNLOCKING THE SOCKET



If the charging cable is locked at the station, the service provider may unlock the cable via this feature.

10.3 - PLUG & CHARGE (OPTIONAL)

PLUG & CHARGE function is only available with OCPP CENTRAL SYSTEM CONNECTED MODE activated. To charge with PLUG & CHARGE, EV shall also support the PLUG & CHARGE function.

10.3.1 - SOCKET EQUIPPED MODEL

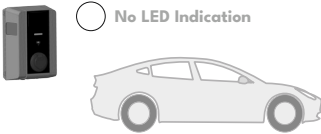
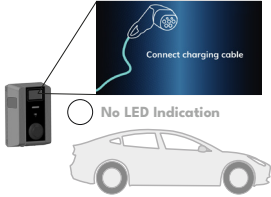
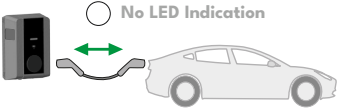
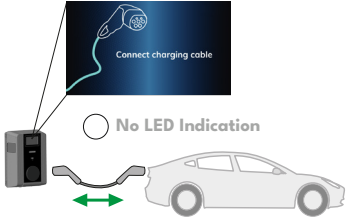
10.3.1.1 - VEHICLE CONNECTION & CHARGING

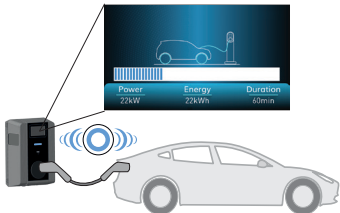

Model Without Display	Model With Display
<p>1 - Ensure that your vehicle and the station is ready for charging.</p> 	<p>1 - Ensure that your vehicle and the station is ready for charging.</p> 
<p>2 - Insert the charging plug to the vehicle inlet and charging station socket outlet.</p> 	<p>2 - Insert the charging plug to the vehicle inlet and charging station socket outlet.</p> 
<p>3 - Charging starts and status indicator LED glows in blue.</p> 	<p>3 - Charging starts automatically, and status indicator LED glows in blue.</p> 

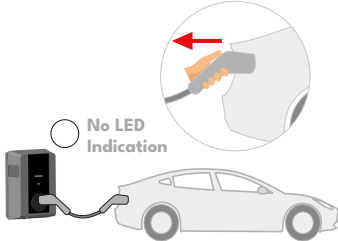
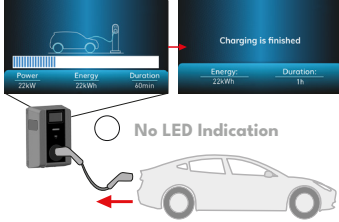
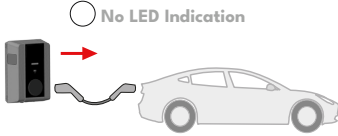
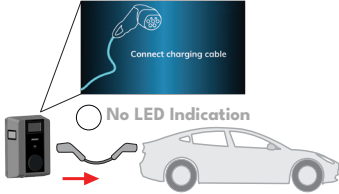
10.3.1.2 - STOP CHARGING

Model Without Display	Model With Display
<p>1- Unplug the charging cable from the vehicle first to stop charging. Do not attempt to remove the plug from the station before unplugging it from the vehicle. Otherwise locking mechanism may get damaged.</p> 	<p>1- Unplug the charging cable from the vehicle first to stop charging. Do not attempt to remove the plug from the station before unplugging it from the vehicle. Otherwise locking mechanism may get damaged.</p> 
<p>2 - Unplug the charging cable from the station.</p> 	<p>2 - Unplug the charging cable from the station.</p> 

10.3.2 - ATTACHED CABLE MODEL

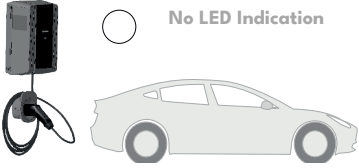
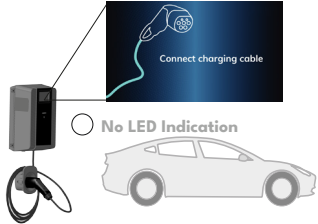
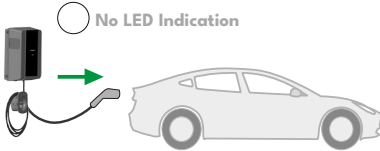
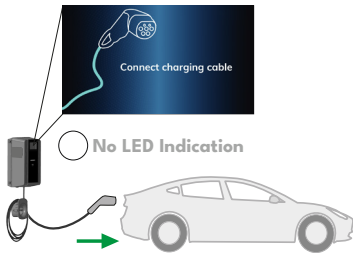
10.3.2.1 - VEHICLE CONNECTION & CHARGING

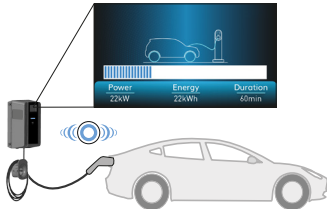
Model Without Display	Model With Display
<p>1 - Ensure that your vehicle and the station is ready for charging.</p> 	<p>1 - Ensure that your vehicle and the station is ready for charging.</p> 
<p>2 - Insert the charging plug to the vehicle inlet and charging station socket outlet.</p> 	<p>2 - Insert the charging plug to the vehicle inlet and charging station socket outlet.</p> 
<p>3 - Charging starts automatically, and status indicator LED glows in blue.</p> 	<p>3 - Charging starts automatically, and status indicator LED glows in blue.</p> 

10.3.2.2 - STOP CHARGING

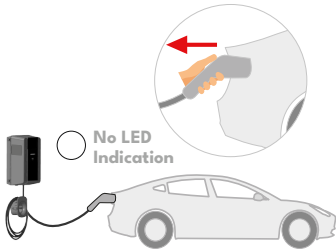
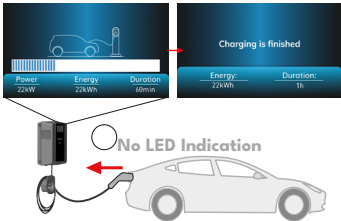
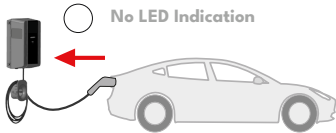
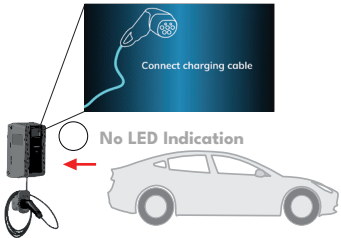
Model Without Display	Model With Display
<p>1- Unplug the charging cable from the vehicle first to stop charging.</p> 	<p>1- Unplug the charging cable from the vehicle first to stop charging.</p> 
<p>2- Insert the charging plug to the charging plug holder of the station.</p> 	<p>2- Insert the charging plug to the charging plug holder of the station.</p> 

All products images are given for as a representative.

11 - MID METER MODELS (OPTIONAL)

It is possible to view the total active energy on the display of the MID meter (products with MID meter).



12 - ERROR AND FAULT CONDITIONS

Due to any fault, in display models, you can see “Out of order!” screen in charging station. The received error code also appears on the display.

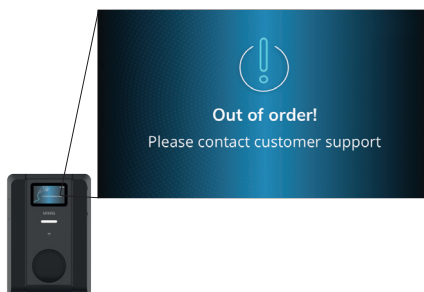

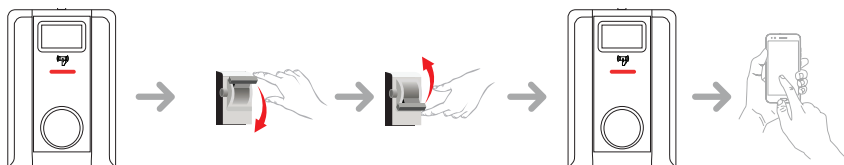

12.1 - GENERAL ERROR CONDITION

If the status information LED is constant red, turn off the charging station and turn on again.
if the LED is still constant red then call an authorized service.



12.2 - OTHER ERROR CONDITIONS

Status Indicator	Problem	Possible Causes	Recommended Solutions
	The status information LED blinks in red. 10 seconds ON 2 seconds OFF	AC supply voltage may not be in the range in the operation manual, grounding connection may not be performed and/or phase/neutral connections may be reversed or the charging station may have a fault.	Please ensure that the voltage is in the specified range and that the grounding connection have been performed. If the button is still solid red, please contact authorized service.
	Even if the status information LED blinks in blue every four seconds, it is not possible to start charging the electric vehicle or to lock the plug in the charging station.	The charging plug may not be connected properly to the charging device or the electric vehicle.	Ensure that the charging plug is connected properly on both sides. Please check if your electric vehicle is in charging mode.
	The status information LED blinks in red	You shall see this error notification if your vehicle is equipped with a battery type that requires ventilation.	This charging station is not suitable to charge such vehicles.

NOTE : If you face a configuration problem in configuring your charger and smartphone please be sure that the bluetooth range is less than 10 meters - stay inside the range.

NOTE : If you face a Wi-Fi connection problem in controlling the charger please restart your router and check the connections.

12.3 - ON BOARD TYPE-A RESIDUAL CURRENT DEVICE

The charging station is equipped with a certified on board designed Type-A residual current device that reacts a DC leakage current higher than 6mA or AC leakage current higher than 30mA. If the charging station goes to error state due to residual current, charging cable must be unplugged from vehicle and then from the charging station to reset this error. If the error state does not resets after unplugging charging cable, please consult to customer care.

13 - CLEANING AND MAINTENANCE

DANGER

- Do not clean your electric vehicle charging device while charging your vehicle.
- Do not wash the device with water.
- Do not use abrasive cloths and detergents. Microfiber cloth is recommended.

Failure to follow these warnings may result in death and serious injuries. Also, it may cause damage to your device.

14 - UK REGULATION CHANGES ACCORDING TO SMART CHARGING (OPTIONAL)

CONFIGURATION WEB INTERFACE SETTINGS

Randomised Delay and Off-Peak Charging Behaviour

- a.** Randomised delay won't be repeated if applied in a charging period (except after power off and second transition to off peak hour, E.g: charging starts at 15:00 and paused at 16:00, when starting at 22:00 again randomized delay will be applied again.)
- b.** Randomised delay and waiting for off-peak charging will be cancelled if user tap RFID card for forced charging (first tap if charging station is in autostart mode, second tap if the charging station is in authorized mode). If the unit is in autostart mode any RFID card will force a charge, if the unit is in authorized mode the authorizing card of that charging session will force charge. Forced Charge will cancel both off-peak hour waiting period and randomized delay for that charging session.
- c.** While starting a charge session, if the time is in a peak period, the charging start will be delayed to the upcoming off-peak period start time. Randomized delay will be applied when the charging (actual energy transfer) starts.
- d.** If the time is in off-peak period, the randomized delay will be applied (if enabled) and then charging will start after delay. (It is only a numerical value and should be 600 by default). During the charging session if the time shifts from off-peak to peak, charging will continue or pause according to the setting "ContinueAfterOffPeakHour".
- e.** If unit has a screen "Waiting for off-peak hour, charging will start at hh:mm" will be shown on the screen while OCPP mode is active.
- f.** If unit has a screen, "Waiting for random delay, Charging will start at hh:mm" will be shown on the screen while OCPP mode and random delay mode are active sync of the time information from the server.
- g.** If a unit can connect to a central system, it will show exact charging start time on the screen. If a unit can not sync local time from the server due to either a connection issue or the unit is used locally without connection, it will only show the remaining time to start the charging session.
- h.** If unit does not have screen then waiting for off-peak hour will be shown on LED as Blue-Red blinking. (will be shut of after 5 mins)
- i.** If unit does not have a screen then randomised delay will be shown on LED as Green blinking.

OCPP mode change config items:

- i.** RandomisedDelayMaxSeconds: [0, 1800] (Default:600, can be set to “0” for disabling)
- ii.** CurrentSessionRandomDelay: random delay value calculated for active charging session. The value will be decremented by 1 minute intervals with time passes. (subject to change)
- iii.** OffPeakCharging: TRUE / FALSE (Default: TRUE)
- iv.** OffPeakChargingWeekend: TRUE / FALSE (Default: FALSE)
- v.** OffPeakChargingTimeSlots: 11:00-16:00, 22:00-08:00 (Default: 11:00-16:00, 22:00-08:00)
- vi.** ContinueAfterOffPeakHour: TRUE / FALSE (Default: FALSE)
- vii.** ContinueChargingAfterPowerLoss: TRUE / FALSE (Default: TRUE)
- viii.** ForcedCharging: TRUE / FALSE (Default: False, OCPP CS may set this to TRUE for overriding randomised delay and off-peak and after the charging session charging station will set this to FALSE again.)

Standalone / Local RFID List:

Webconfig General Settings menu “Smart Charging” tab:

Off-peak charging function will be active if and only if device is connected to the central system.

For the unit in standalone mode the settings will be as above. For Standalone modes, off peak charging will be hidden because of the time sync issue.

Randomised Delay Maximum Duration, can take values between 0 and 1800.



Disposal

The crossed-out wheeled Bin symbol on the product or its packaging indicates that the device may not be disposed of with household waste, rather requires separate disposal. Old devices delivered to Recycling centers etc. which are appropriate for waste electrical-electronic devices, can then be obtained free of charge from these centers. You can get the addresses from your municipality or local authority. When purchasing a new device, old devices that have essentially the same functions and are of the same type as the new device can be returned to dealers free of charge. Please contact your dealer for the procedure for returning the old device when the new device is delivered. Please note that the persons concerned are responsible for deleting personal data from the device to be disposed of. The device may contain substances that can endanger the environment and human health if disposed of incorrectly. Material recycling helps reduce waste and conserve resources. Ensuring that old devices are collected and recycled separately will help prevent damage to the environment and human health.

VESTEL

MOBILITY

